



SERVICE INFORMATION	10-1
TROUBLESHOOTING	10-1
CAM CHAIN REMOVAL	10-2
CAMSHAFT REMOVAL	10-2
ROCKER ARM REMOVAL	10-5
ROCKER ARM INSTALLATION	10-6
CAMSHAFT INSTALLATION	10-7
VALVE TIMING ADJUSTMENT	10-9

SERVICE INFORMATION

• **WORKING PRACTICE**

Camshaft lubricating oil is fed from the oil filter to the front bearing through an oil control orifice located in the engine case, and to the rear bearing through an oil control orifice in the camshaft rear holder.

Be sure these orifices are not clogged and that the O-rings and dowel pins are in place before assembling the engine.

Before assembling the camshaft, lubricate the bearings with engine oil and pour 100 cc of engine oil into the engine block oil pockets to provide initial lubrication.

• **SPECIAL TOOLS**

GEAR HOLDER 07924-4150000
LOCK NUT SOCKET WRENCH (17 x 27 mm) 07907-4150000

• **SPECIFICATIONS**

			Standard	Service Limit
Camshaft	Cam lift	IN	37.046 mm (1.4585 in.)	36.058 mm (1.4196 in.)
		EX	37.015 mm (1.4573 in.)	36.027 mm (1.4184 in.)
	Journal O.D.	Front	21.959-21.980 mm (0.8645-0.8654 in.)	21.910 mm (0.8526 in.)
		Rear	25.959-26.980 mm (1.0220-1.0622 in.)	25.910 mm (1.0201 in.)
Rocker arms and shafts	Arm I.D.		14.016-14.027 mm (0.5518-0.5522 in.)	14.046 mm (0.5530 in.)
	Shaft O.D.		13.982-14.000 mm (0.5505-0.5512 in.)	13.966 mm (0.5510 in.)
	Camshaft holder I.D.		22.000-22.021 mm (0.8661-0.8670 in.)	22.050 mm (0.8681 in.)
	Camshaft block journal I.D.		26.000-26.021 mm (1.0236-1.0244 in.)	26.170 mm (1.0303 in.)

TROUBLESHOOTING

Excessive Noise

1. Incorrect cam chain adjustment
2. Incorrect valve adjustment
3. Worn or damaged rocker arms or camshaft
4. Worn or damaged cam chain tensioner or cam chain guide
5. Worn cam sprocket teeth
6. Worn camshaft holder



CAMSHAFT/CAM CHAIN

CAM CHAIN REMOVAL

Remove the flywheel. (Page 8-4).
Remove the chain guide set plate B bolts.
Remove the chain guide set plate B with spring from the crank shaft.
Free the chain guide set plate from the spring.

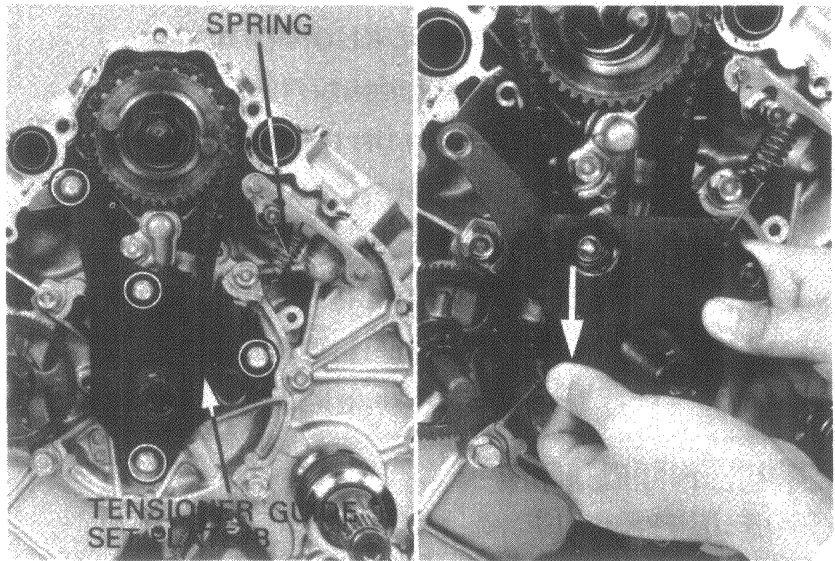

Remove the lock bolt and collar.
Remove the tensioner, cam chain guide and chain guide set plate A.
Remove the tensioner and cam chain guide.
Remove the 7 mm dowel bolts and remove the cam sprocket and cam chain.

Check the cam chain guide and tensioner for wear or damage to the slipper surfaces.

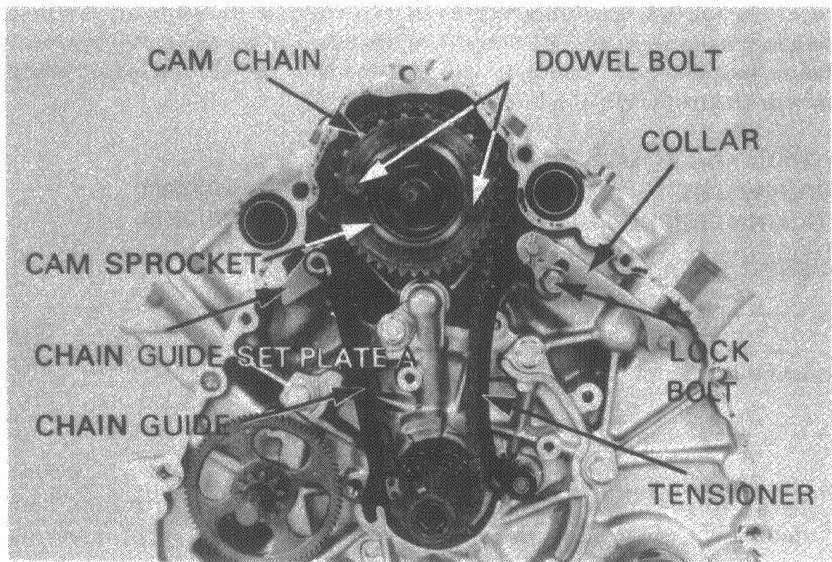

CAMSHAFT REMOVAL

Temporarily install the cam sprocket.
Hold the cam sprocket with a GEAR HOLDER to prevent it from turning.
Loosen the 27 mm nut and remove the cam sprocket and cam sprocket boss.

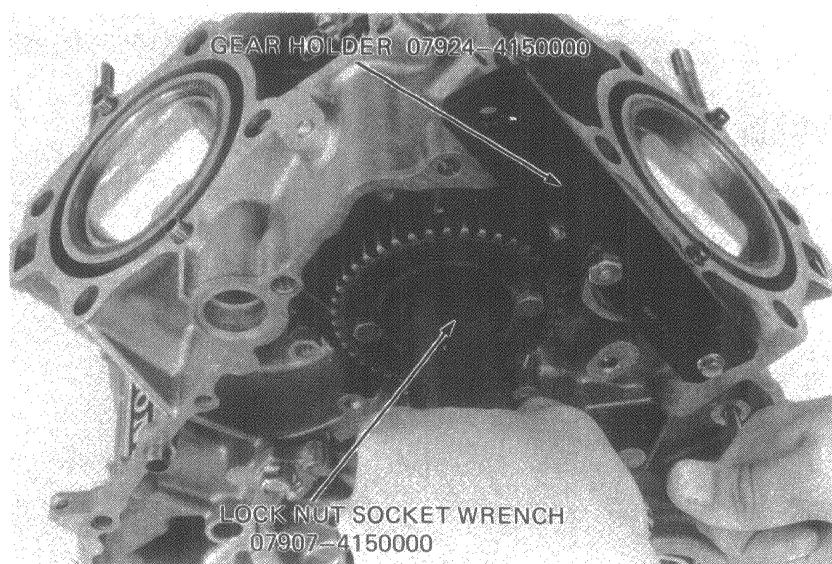



Remove the cooling fan (Page 9-5).
Remove the camshaft holder.

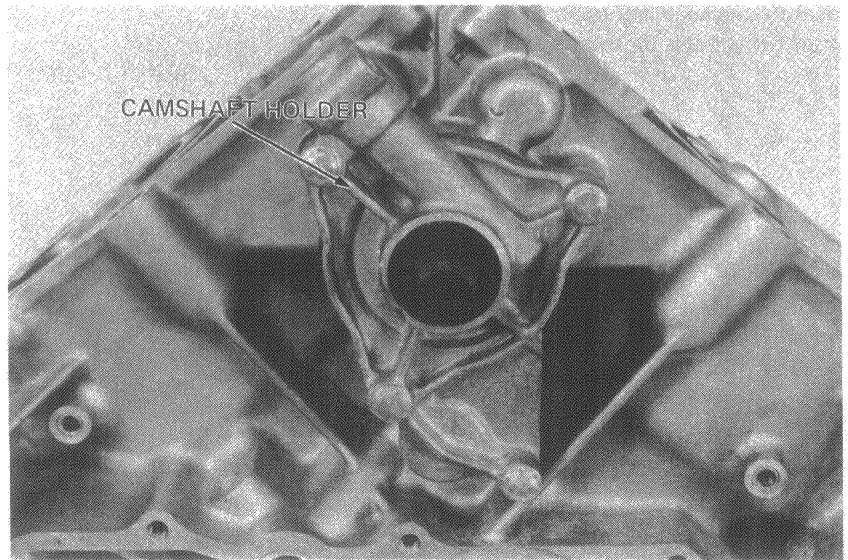

Remove the camshaft from the front.

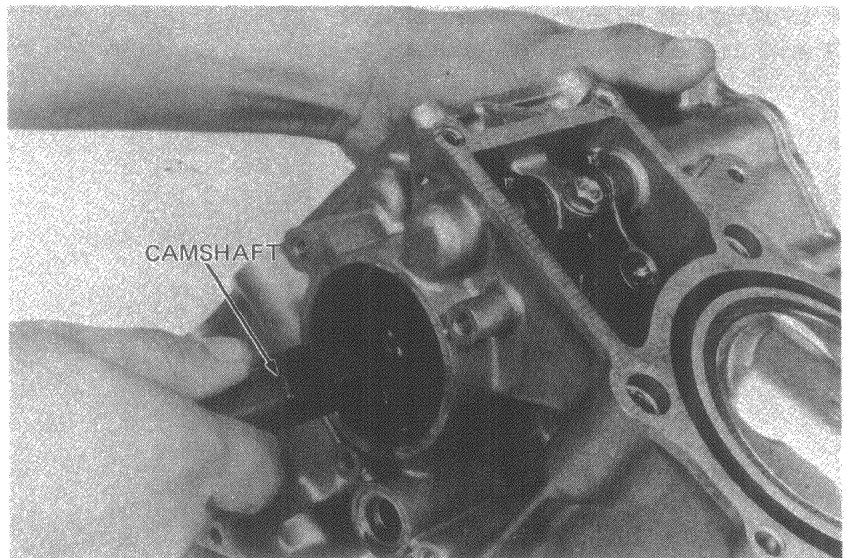

● **CAMSHAFT INSPECTION**

Measure the O.D. of each camshaft bearing journal.

Calculate the journal and bearing clearance.

SERVICE LIMIT: 0.260 mm (0.0102 in.)

Inspect the worn gear for wear or damage.

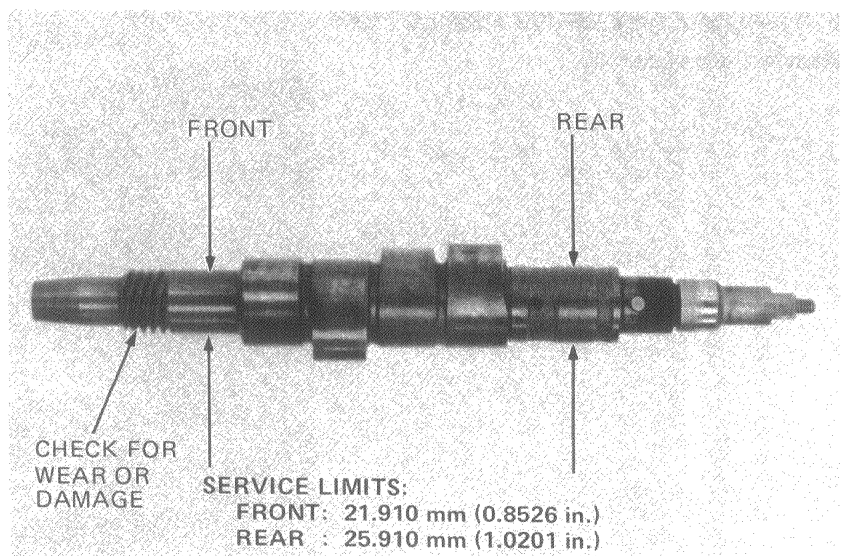



CAMSHAFT/CAM CHAIN

Measure the height of each cam lobe.
Inspect the lobes for wear or damage.

SERVICE LIMITS:

IN : 36.058 mm (1.4196 in.)
EX: 36.027 mm (1.4184 in.)

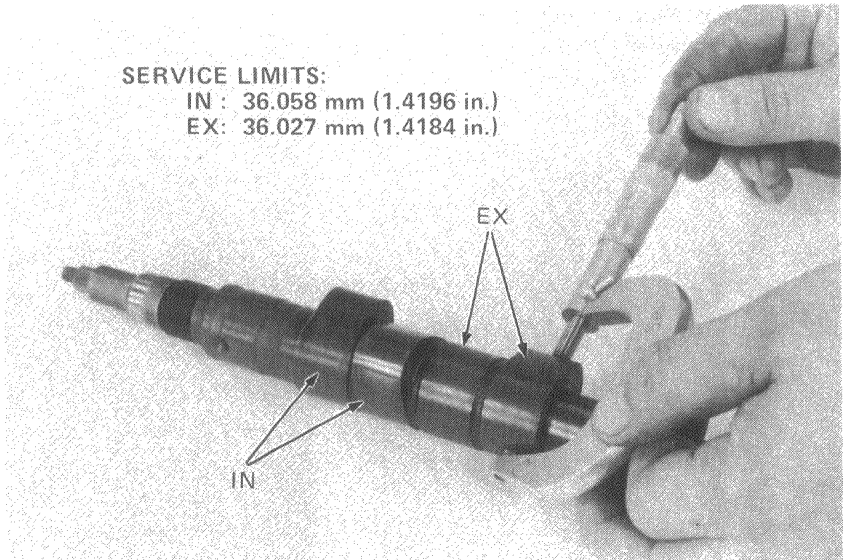

● **CAMSHAFT HOLDER INSPECTION**

Measure the camshaft holder I.D. as shown.

SERVICE LIMIT: 22.050 mm (0.8681 in.)

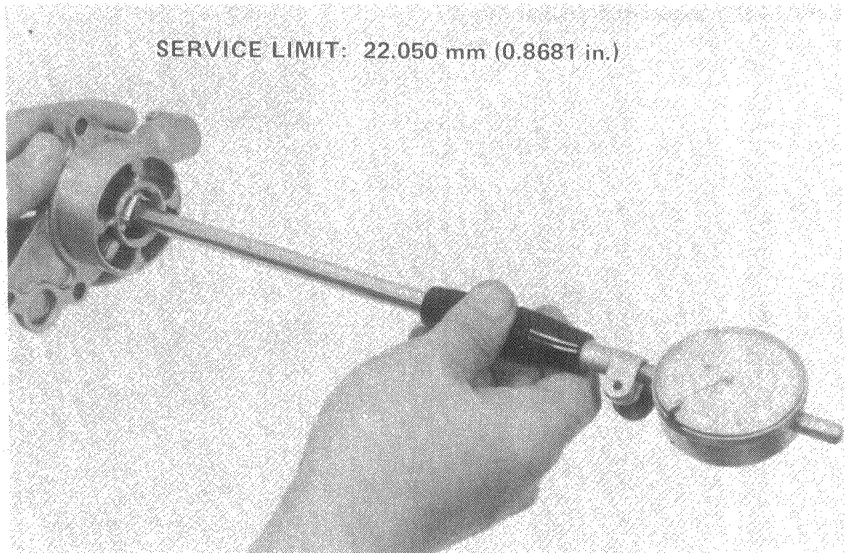

● **CAMSHAFT BEARING INSPECTION**

Measure the bearing I.D.

SERVICE LIMIT: 26.170 mm (1.0303 in.)

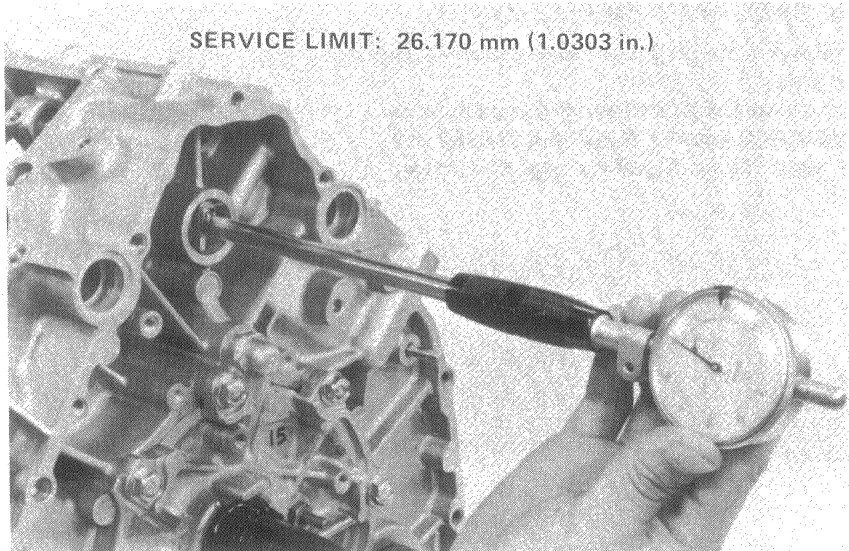



ROCKER ARM REMOVAL

Remove the rocker arm shaft bolts.

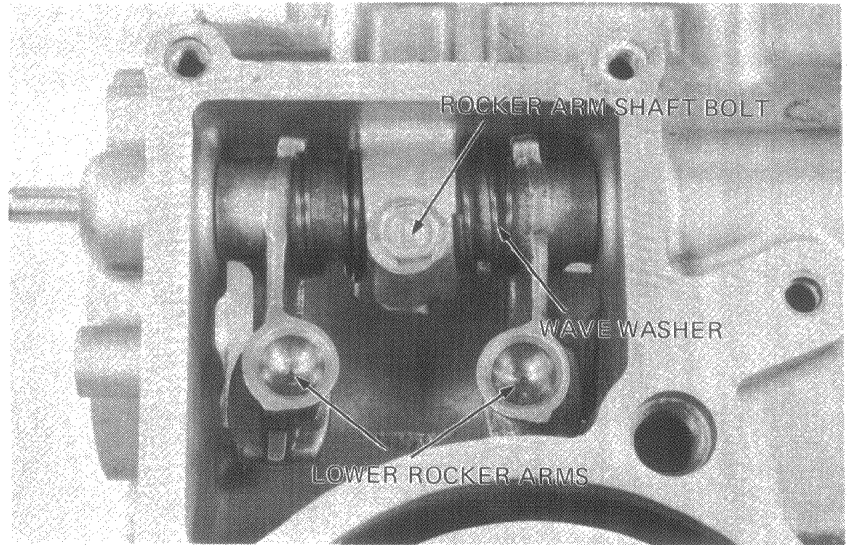

Screw a 6 mm bolt into the rocker arm shaft.
Remove the rocker arm shaft.
Remove the rocker arm and wave washer.

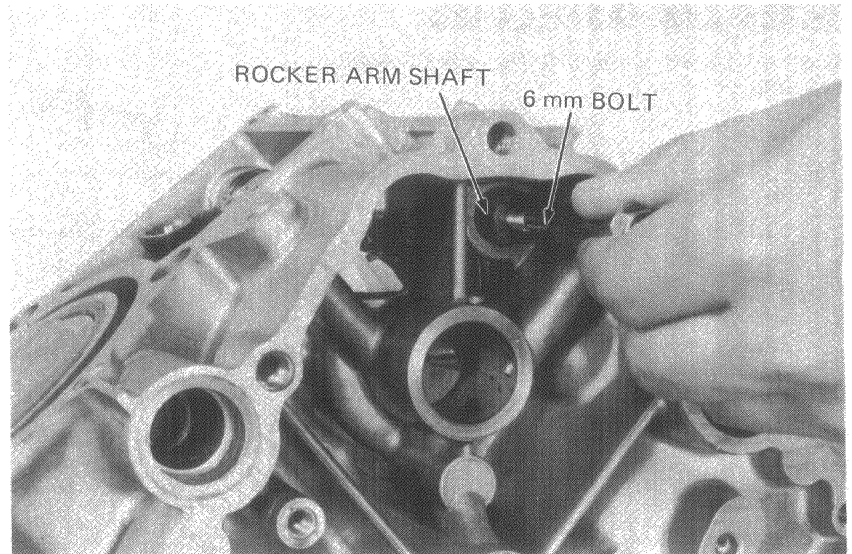

• ROCKER ARM INSPECTION

Inspect the rocker arms for wear or damage to the camshaft contact surfaces, or clogged oil holes.

Measure the I.D. of each rocker arm.

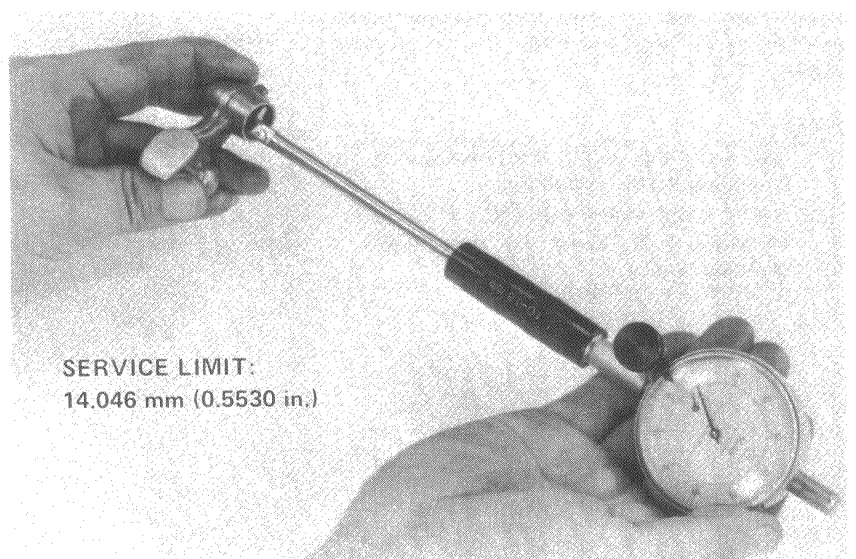

SERVICE LIMIT:
14.046 mm (0.5530 in.)



CAMSHAFT/CAM CHAIN

● **ROCKER ARM SHAFT INSPECTION**

Measure each rocker arm shaft O.D.
Inspect the shaft for wear damage.
Calculate the clearance of the shaft and the
rocker arm.

SERVICE LIMIT: 0.08 mm (0.0031 in.)

SERVICE LIMIT: 13.966 mm (0.5510 in.)

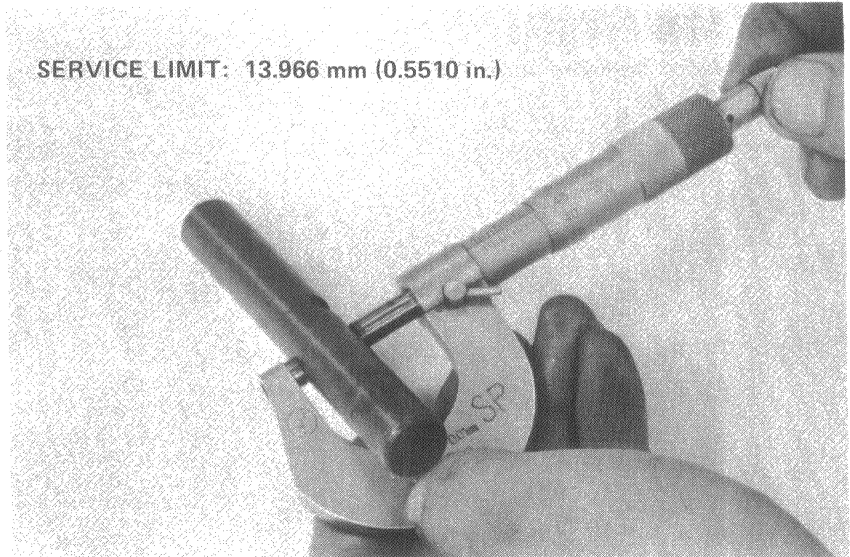

ROCKER ARM INSTALLATION

Install the rocker arms with the offset toward
the inside.

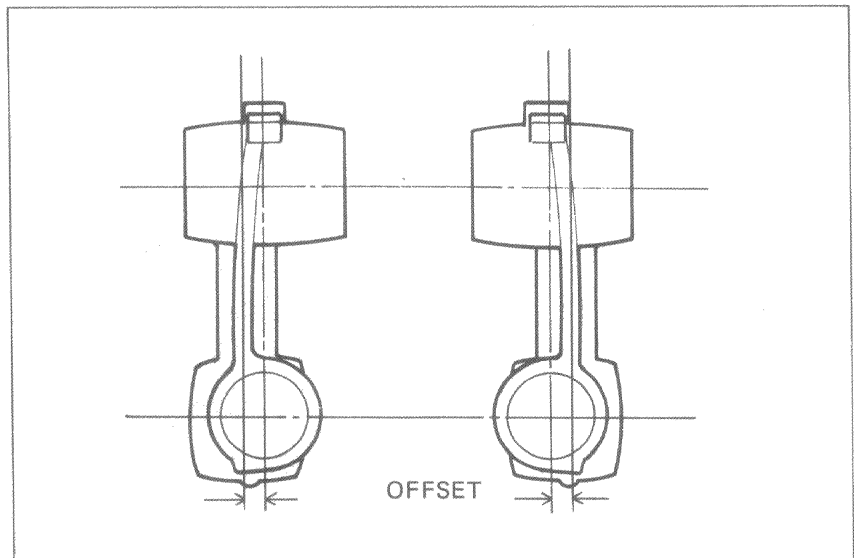

Install the rocker arms and thrust springs in the
cylinder block, and then insert the rocker arm
shafts.



NOTE

- Lubricate the rocker arm shafts with engine oil before installation.
- Install each rocker arm shaft with the threaded end facing the rear (cam sprocket side).

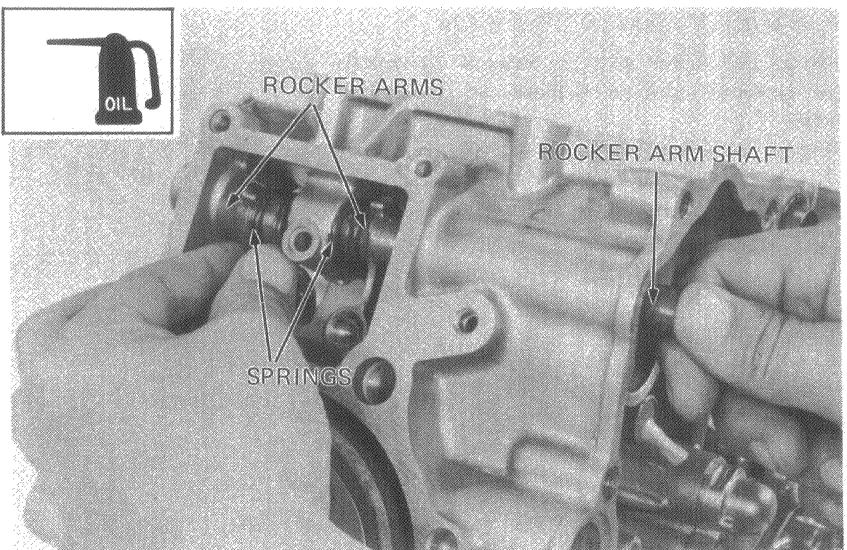



Rotate the rocker arm shaft with a screwdriver to align with the lock bolt hole. Install the lock bolt.

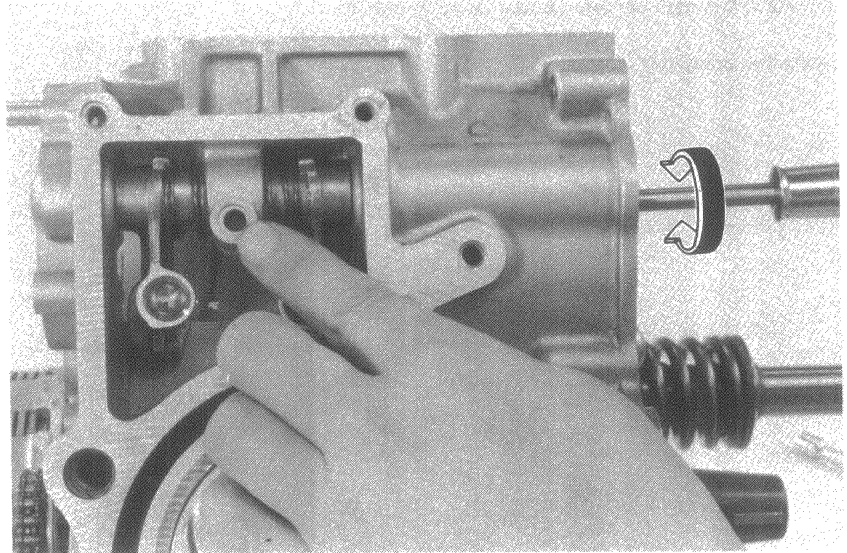

CAMSHAFT INSTALLATION

Lubricate the camshaft journals with molybdenum disulfide grease.
Install the camshaft thrust washer.
Insert the camshaft from the front.

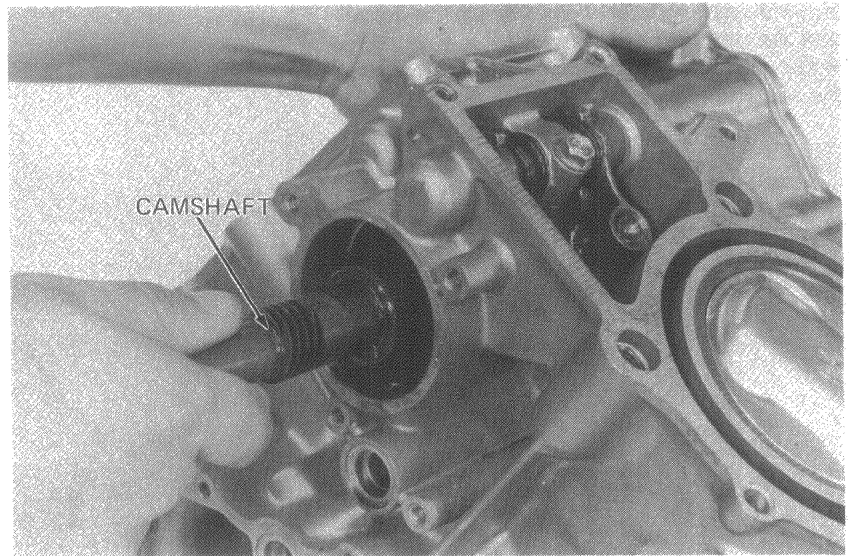

Install the camshaft holder gasket, O-ring, and collar.

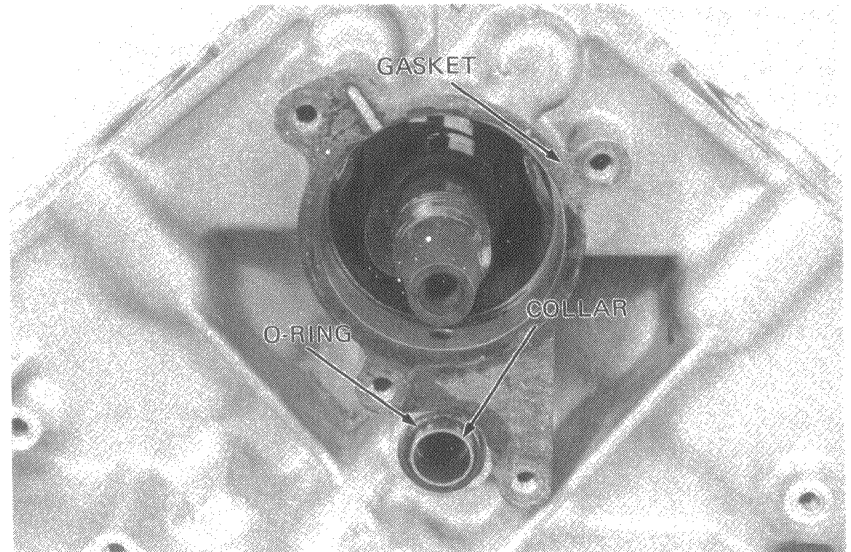



CAMSHAFT/CAM CHAIN

Lubricate the cam holder oil seal lip with engine oil.
Install the camshaft holder.

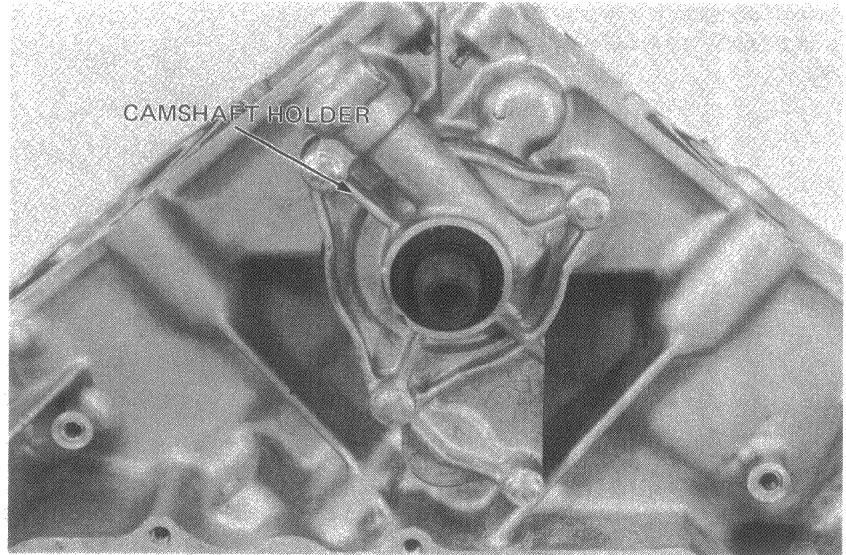

Install the cam sprocket boss aligning the cutout with the camshaft dowel pin.
Install the lock nut and lock washer and tighten the nut temporarily.

NOTE

Install the lock washer with the mark "OUTSIDE" facing out.

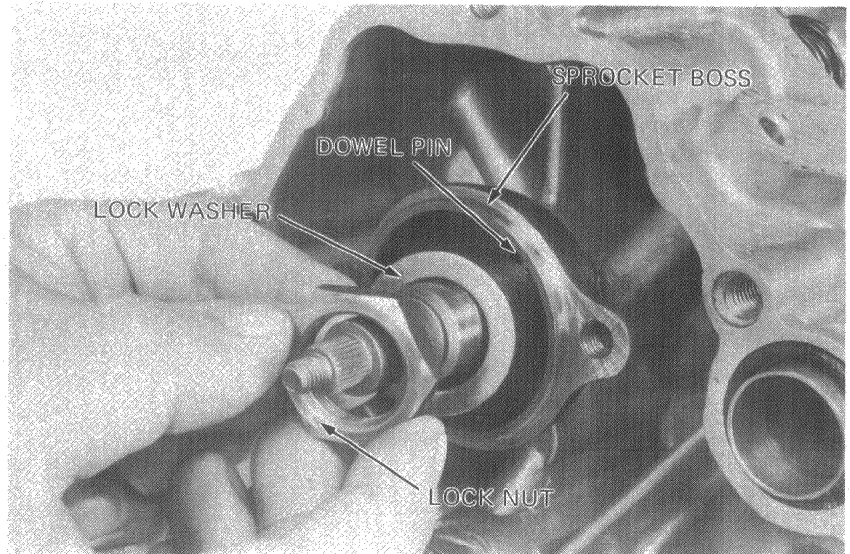

Install the cam sprocket and finger tighten the bolts.
Hold the cam sprocket with the GEAR HOLDER.
Torque the lock nut.
Remove the cam sprocket.

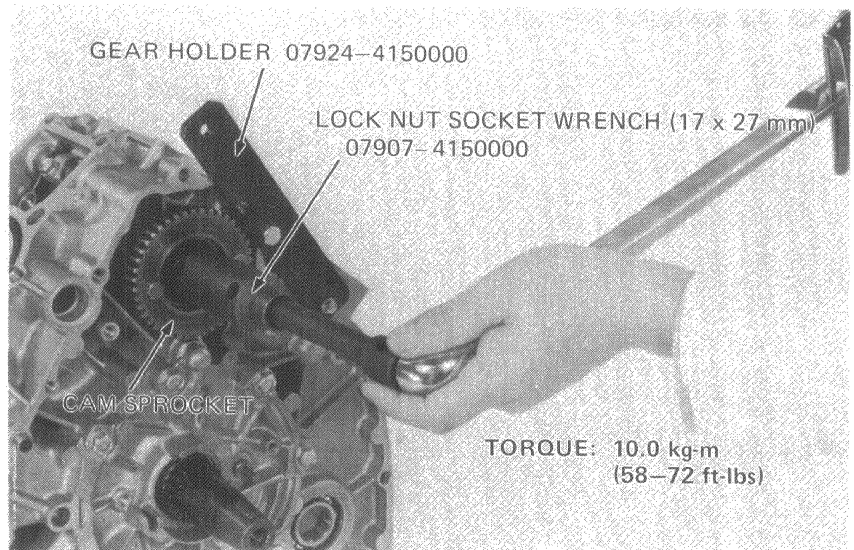



VALVE TIMING ADJUSTMENT

Align the holes in the cam sprocket boss with the aligning marks on the cylinder block.

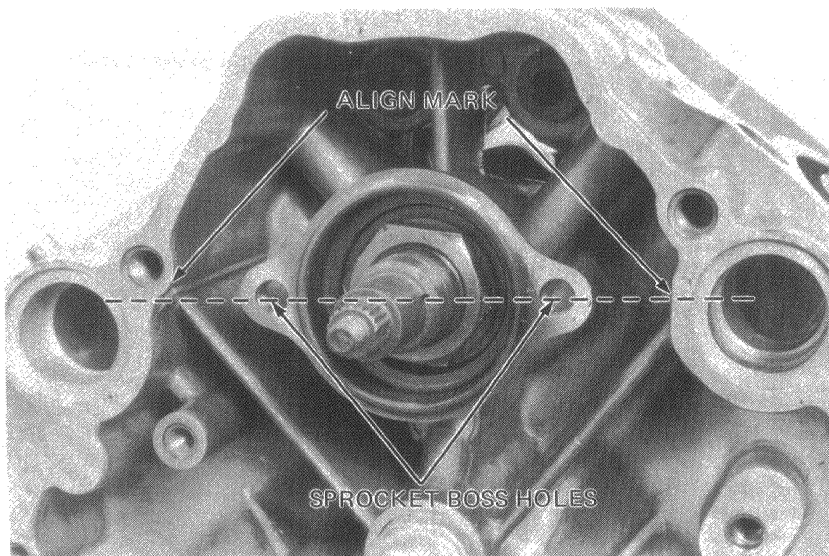

Rotate the crankshaft to bring the left piston to TDC.

Verify the valve timing by observing the following:

- Make sure the cam sprocket bolts are in line with the aligning marks on the cylinder block.
- Check that the flywheel woodruff key aligns with the index mark on the crankshaft cap.

NOTE

When inspecting the valve timing, push the cam chain from the right side so the tensioner-side of the chain is pulled taut.

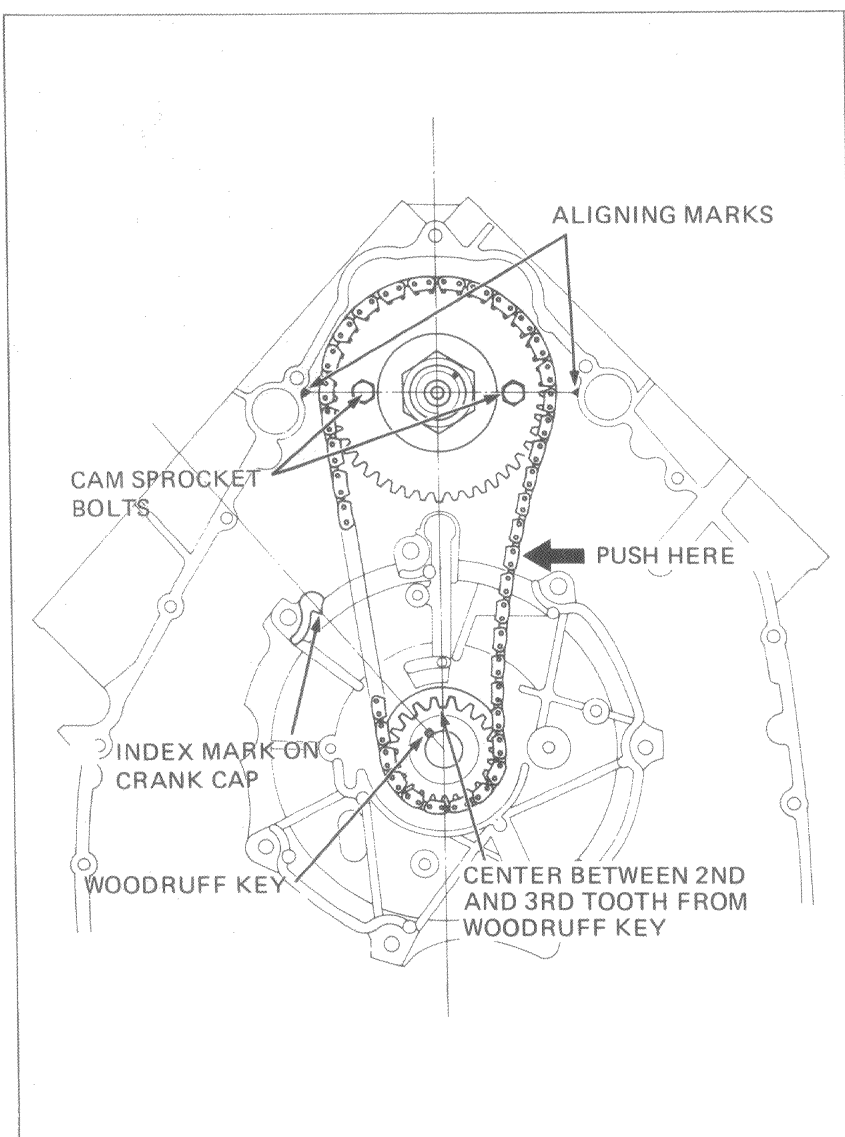



CAMSHAFT/CAM CHAIN

Hold the camshaft with the LOCK NUT SOCKET WRENCH.
Torque the cam sprocket bolts.

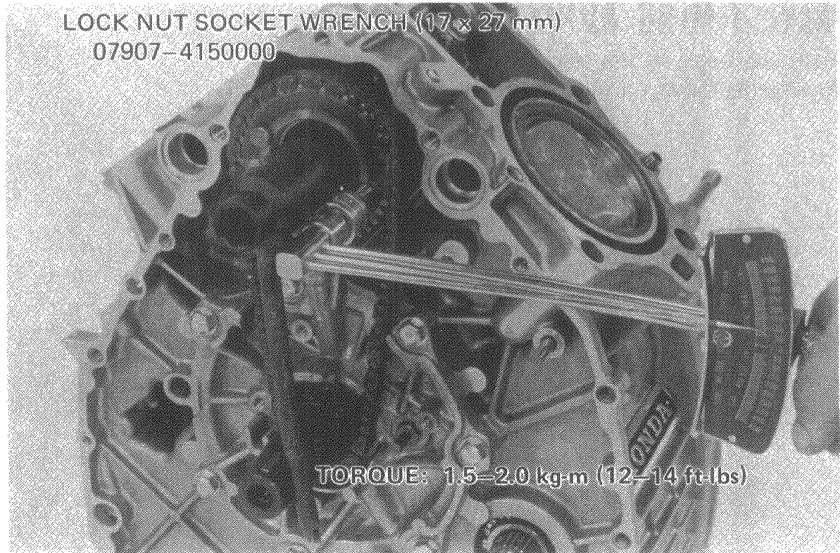

Install the chain guide set plate A, cam chain guide and cam chain tensioner.
Install the tensioner spring.
Install the O-ring on the lock nut.
Slide the collar into the tensioner arm and install the lock bolt. Do not tighten the lock bolt at this time.

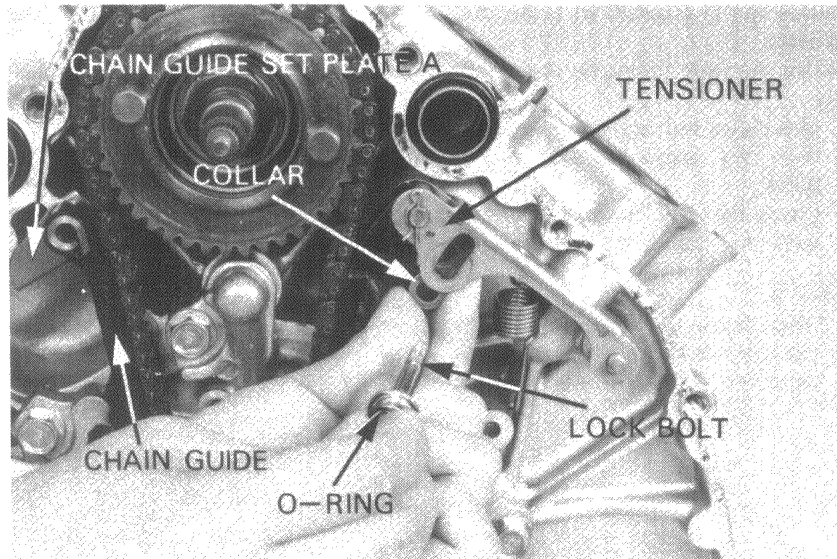

Hook the spring on the chain guide set plate B and install the set plate B.
Tighten the 6 mm bolt.
Tighten the lock bolt.

TORQUE: 0.8-1.2 kg-m (6-9 ft-lb)

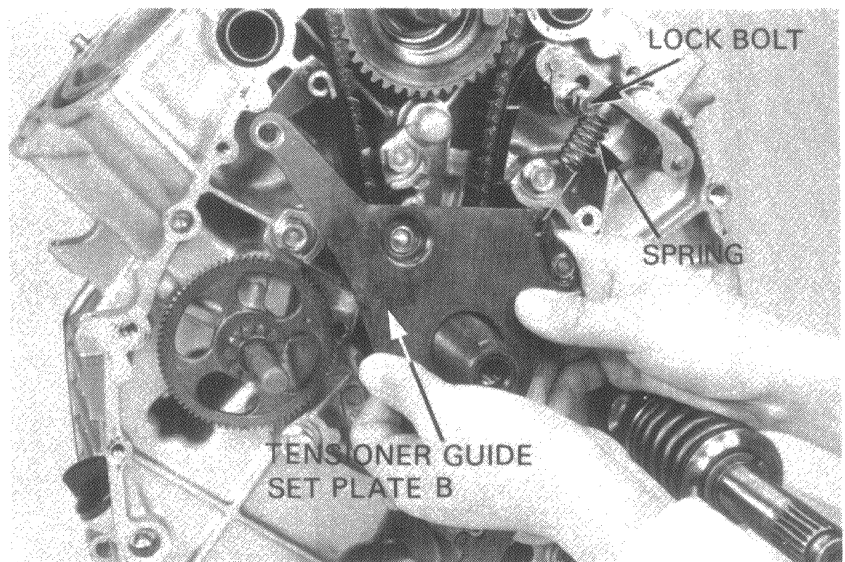



HONDA
CX500

CAMSHAFT/CAM CHAIN

Pour about 100 cc of engine oil into the oil
reservoir of the cylinder block.

