



8. A.C. GENERATOR/ FLYWHEEL/REAR COVER

SERVICE INFORMATION	8-1	STARTER CLUTCH OUTER INSTALLATION	8-6
COMPONENTS REMOVAL	8-2	FLYWHEEL INSTALLATION	8-7
FLYWHEEL REMOVAL	8-4	COMPONENTS ASSEMBLY	8-8
STARTER CLUTCH OUTER REMOVAL	8-5		

SERVICE INFORMATION

• WORKING PRACTICE

Care should be taken to prevent the A.C. generator and pulser from being damaged when disassembling and reassembling them. When the C.D.I. pulser stator is removed, be sure to align the timing mark on the stator with the index mark on the case cover during reassembly.

The A.C. generator stator can be serviced without removing the A.C. generator assembly.

• SPECIAL TOOLS

Special tools	
SOCKET WRENCH (17 x 27 mm)	07907-4150000
GEAR HOLDER	07924-4150000
TORX DRIVER BIT (T40)	07703-0010100
Common tools	
EXTENSION BAR HANDLE	07716-0020500
ROTOR PULLER	07733-0020000
BEARING DRIVER HANDLE (A)	07749-0010000
BEARING DRIVER OUTER (52 x 55 mm)	07746-0010400
BEARING DRIVER PILOT (22 mm)	07746-0041000



COMPONENTS REMOVAL

Remove the engine from the frame (Page 5-2).
 Remove the rear cover (Page 9-6).

• REAR COVER DISASSEMBLY

Remove the water pump mechanical seal (Page 9-6).

Remove the starter motor.

Remove the C.D.I. pulser cover and neutral switch.

Remove the neutral cord guide.

Remove the final shaft oil seal.

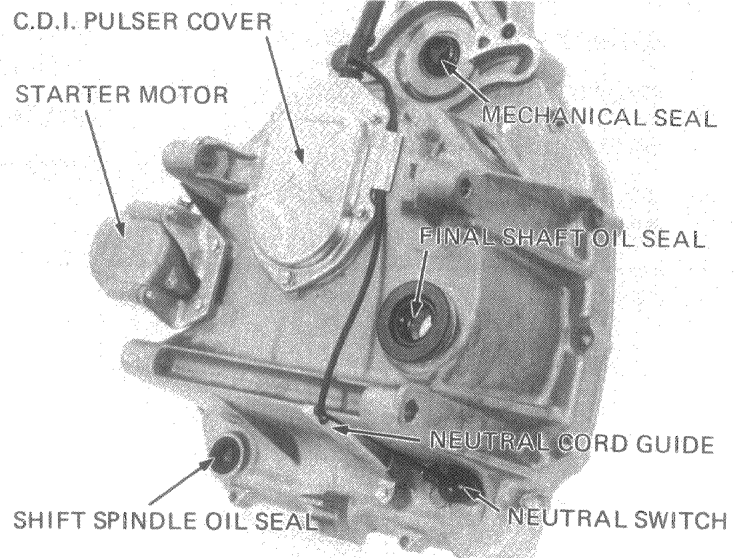

Disconnect the wires at the pulser.
 Remove the pulser stator.

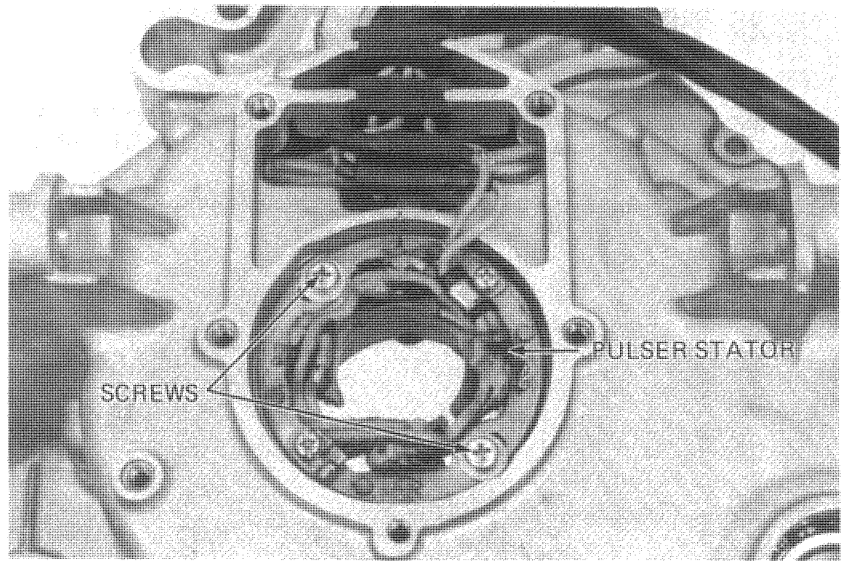

Remove the generator stator and right and left fixed pulsers.

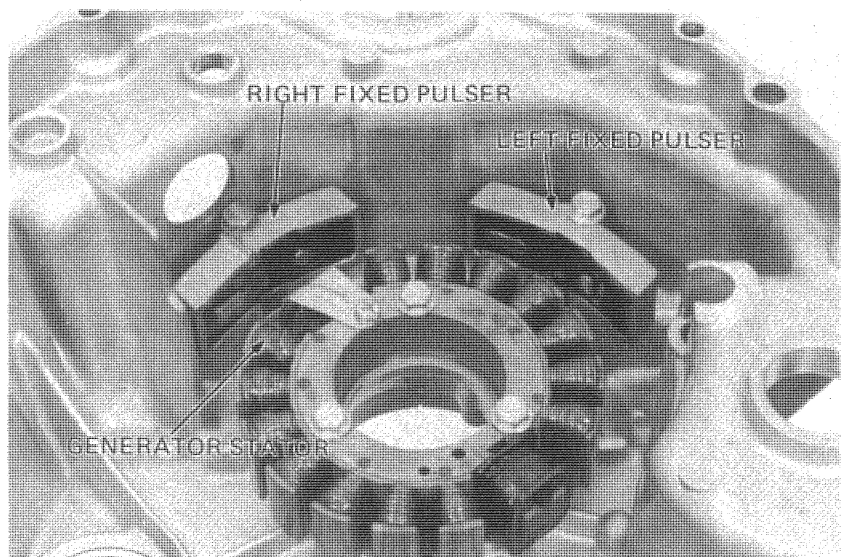



Remove the gearshift spindle oil seal.
Drive the final shaft bearing out.

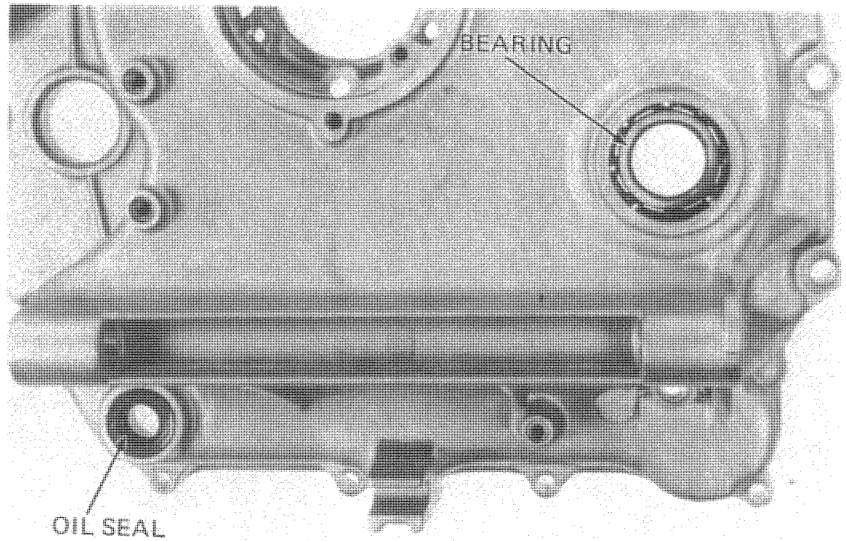

• NEUTRAL SWITCH INSPECTION

Check the neutral switch for continuity between the top and bottom terminals. The switch is normal if there is continuity.

Check for shorts between the top terminal and body ground. Replace the switch if there is continuity.

Inspect the neutral switch wire.

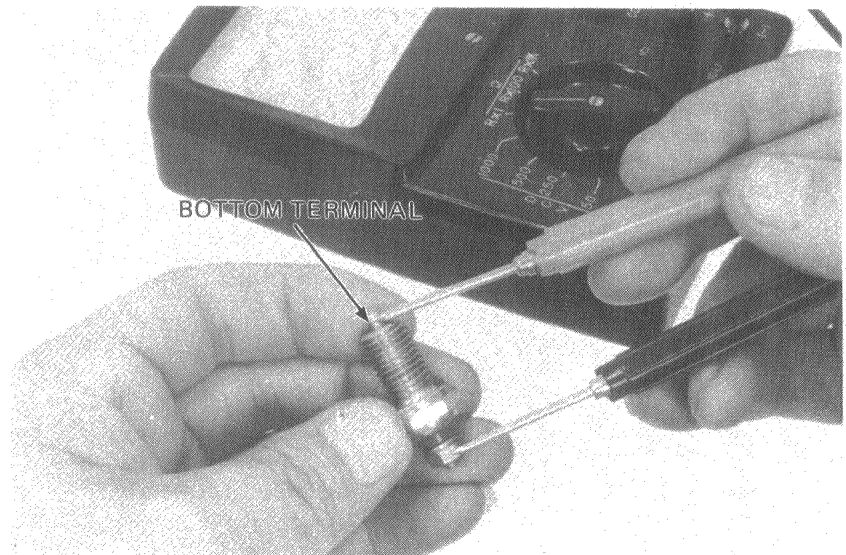
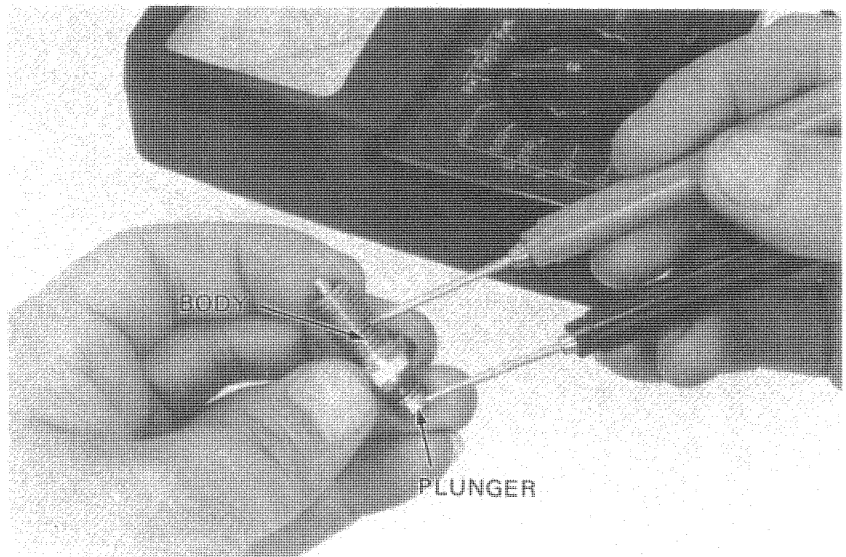

- STARTER MOTOR INSPECTION (Page 18-3)
- C.D.I.PULSER INSPECTION (Page 17-5)
- A.C.GENERATOR INSPECTION (Page 17-5)



FLYWHEEL REMOVAL

Remove the transmission cover (Section 7).
Attach the GEAR HOLDER to the driven gear.

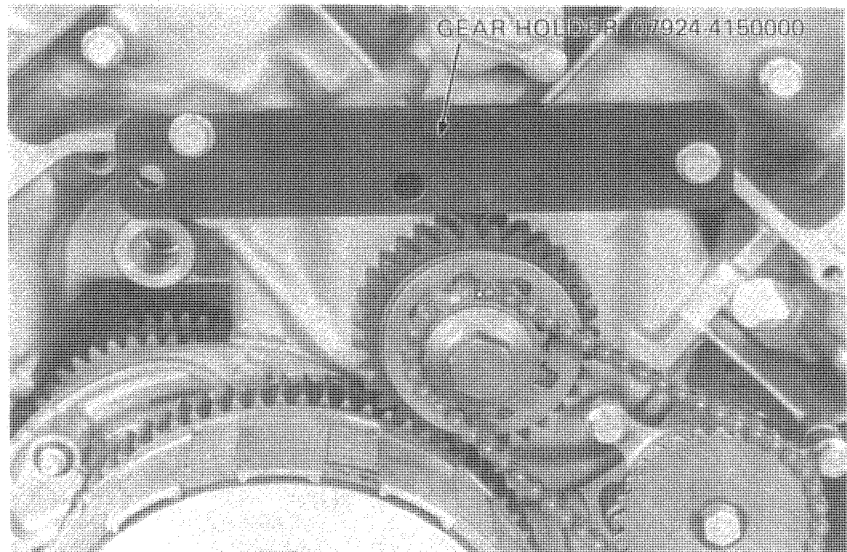

Remove the C.D.I. pulser rotor.
Remove the flywheel bolt.

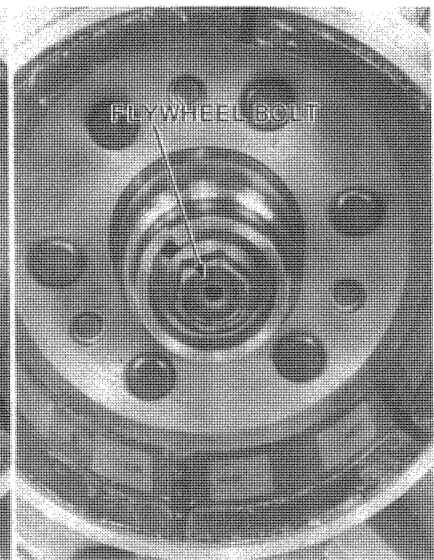
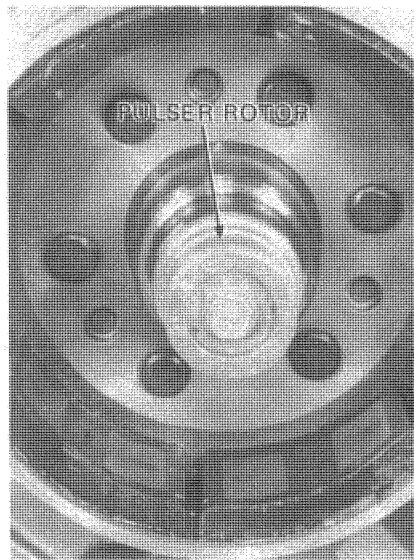

Remove the flywheel.

NOTE

- Care should be taken not to damage the pulser pick-up on the flywheel outer periphery.
- Use the ROTOR PULLER to remove the flywheel.

Remove the reduction gear shaft.

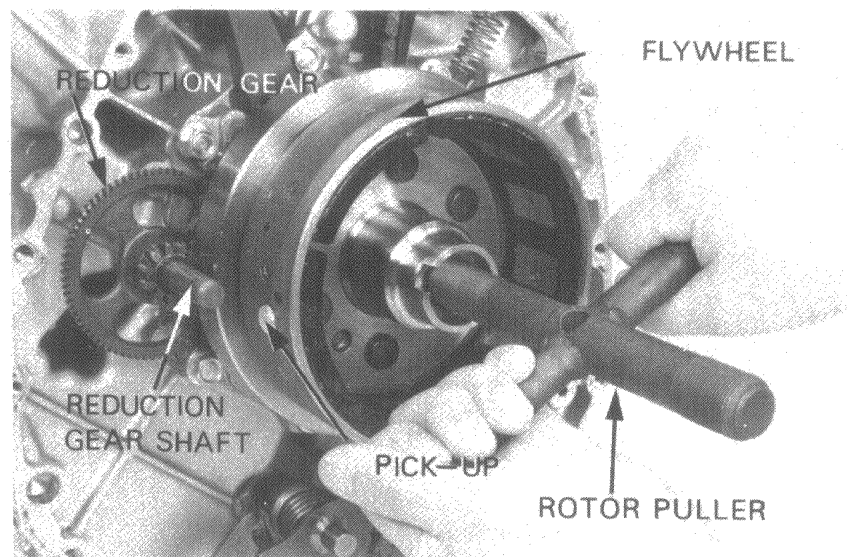



● **REDUCTION GEAR INSPECTION**

Inspect the reduction gear teeth for damage.
Measure the reduction gear I.D.
Measure the reduction gear shaft O.D.
Calculate the gear to shaft clearance.

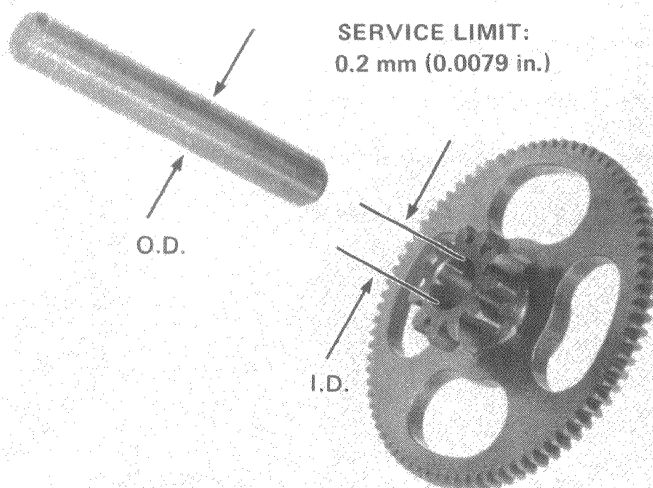

● **STARTER DRIVE GEAR INSPECTION**

Check the drive gear for damage, excessive wear, indentations or other faults. Measure the gear I.D.

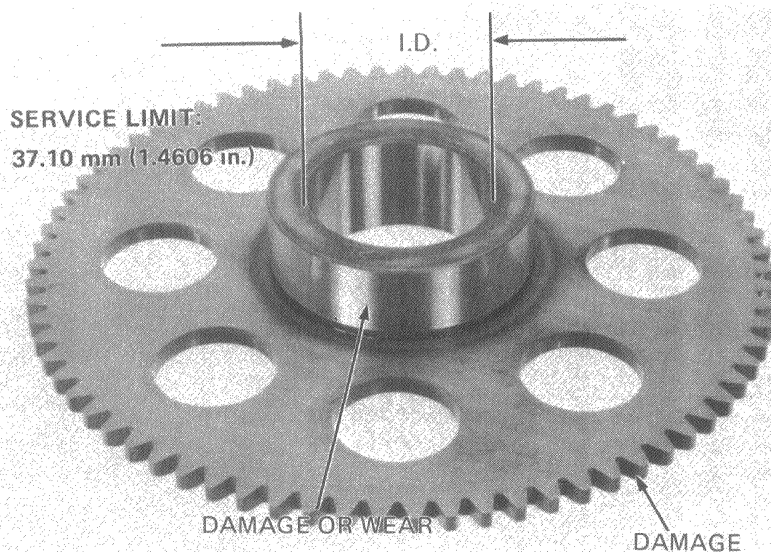

STARTER CLUTCH OUTER REMOVAL

Remove the starter clutch rollers, springs and plunger.
Remove the TORX bolts.

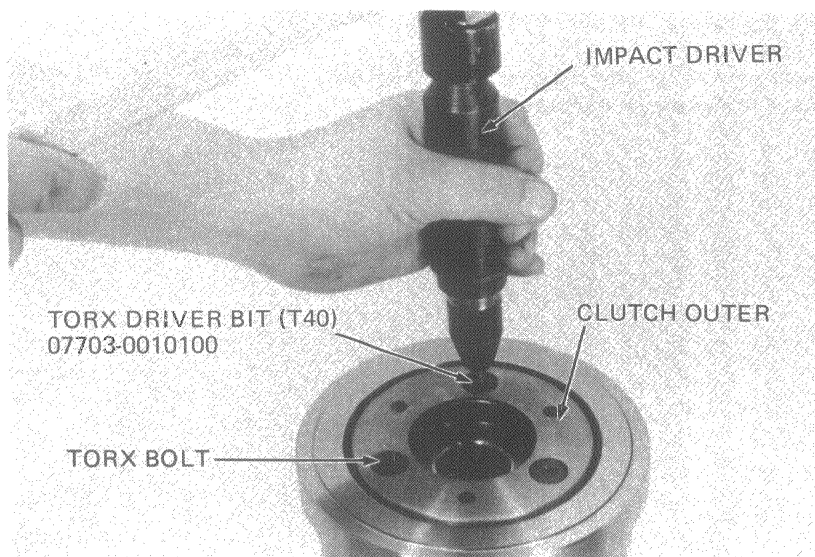



STARTER CLUTCH OUTER INSPECTION

Inspect the rollers for freedom of movement in their grooves.

Inspect each roller and replace if it is worn or damaged.

Inspect the clutch outer for damaged or worn roller surfaces.

Examine the springs and plungers for distortion or excessive wear.

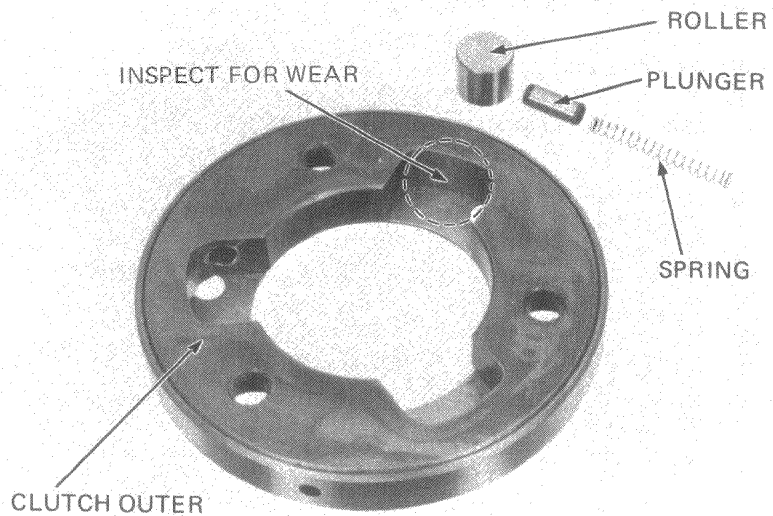

STARTER CLUTCH OUTER INSTALLATION

Slide the clutch outer into the flywheel, aligning the holes with the dowel pins in the flywheel.

Install and torque the TORX bolts.

NOTE

Replace used TORX bolts.

TORQUE: 2.0-2.5 kg-m (14-17 ft-lbs)

NOTE

Coat the threads and undersides of the TORX bolts with a locking agent, prior to installation.

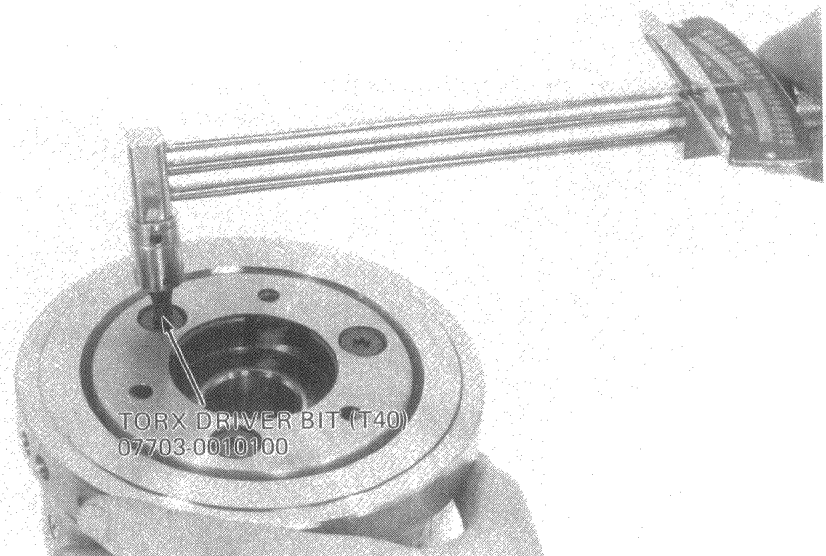

Slide the spring into the plunger and install in the clutch outer.

Position the roller into place while holding the plunger with a screwdriver as shown.

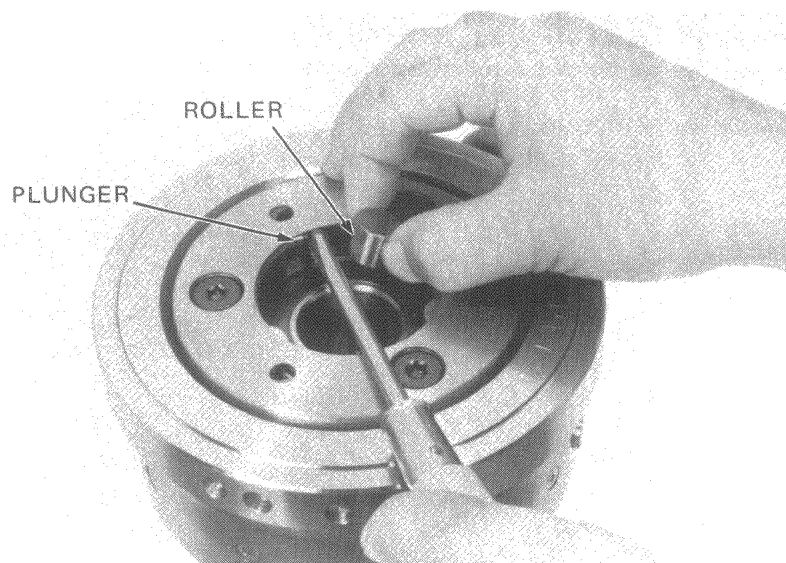



Install the washer.
Install the starter drive gear on the clutch outer.

NOTE

Rotate the drive gear in the counterclockwise direction to aid installation.

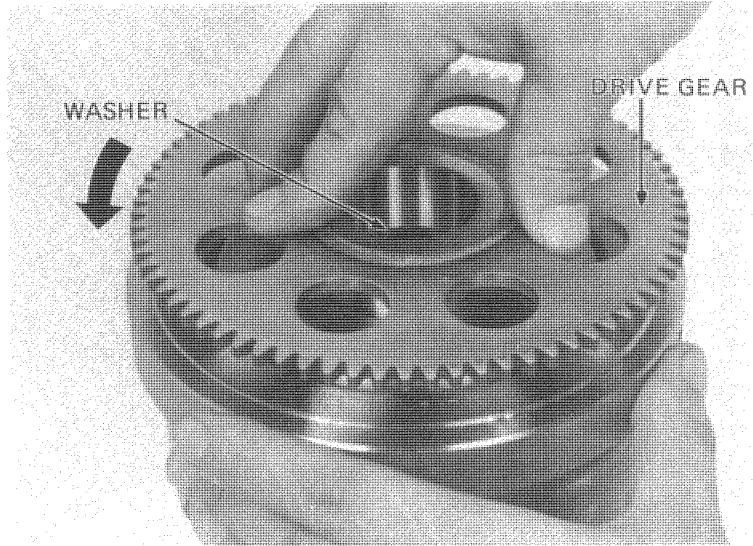

Install the needle roller bearing in the drive gear.

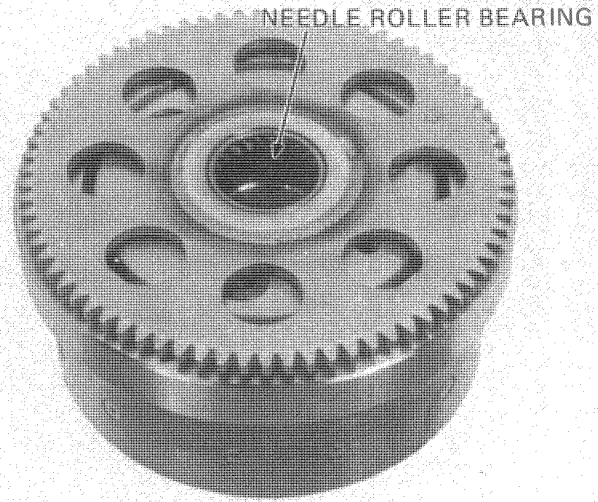

FLYWHEEL INSTALLATION

Install the reduction shaft, thrust washers and reduction gear.

NOTE

Use two thrust washers, one on each side of the reduction gear.

Install the flywheel and torque the flywheel center bolt.

TORQUE: 8.0–10.0 kg-m (58–72 ft-lbs)

NOTE

Align the key in the crankshaft with the keyway in the flywheel.

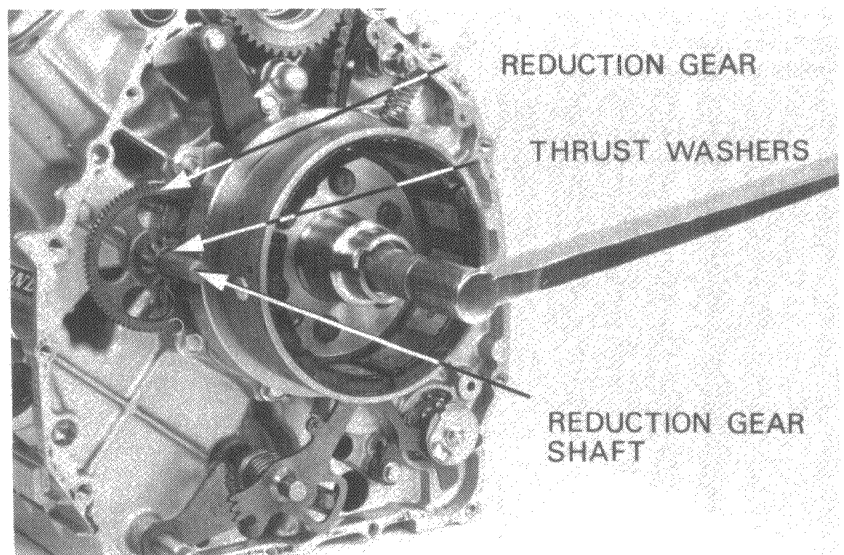



Install the C.D.I. pulser rotor aligning the holding tab with the cutout in the flywheel.

NOTE

Replace the pulser rotor and stator as a set.

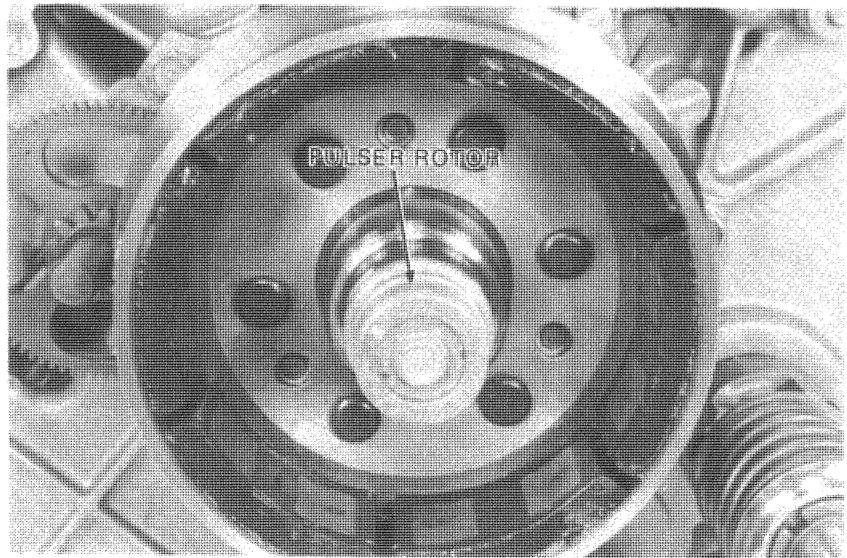

COMPONENTS ASSEMBLY

Install the final shaft bearing.

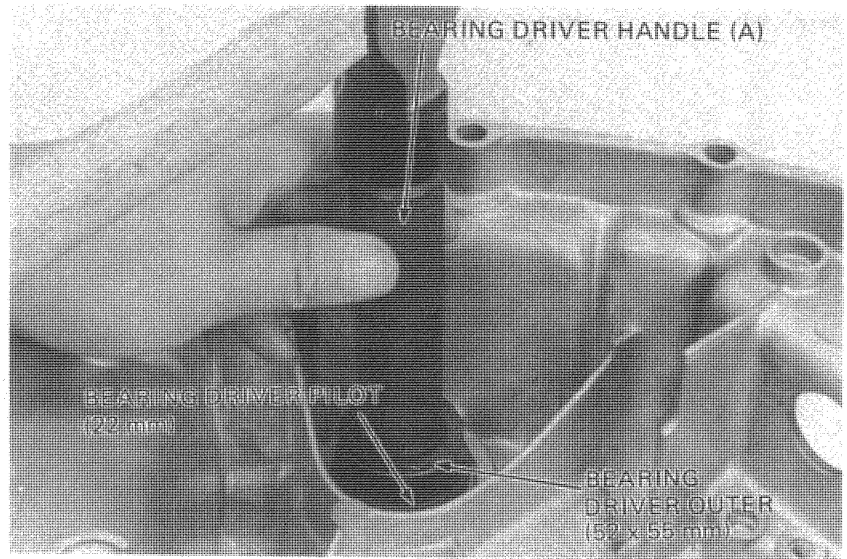

Install the final shaft oil seal and gear shift spindle oil seal.
Install the neutral switch.

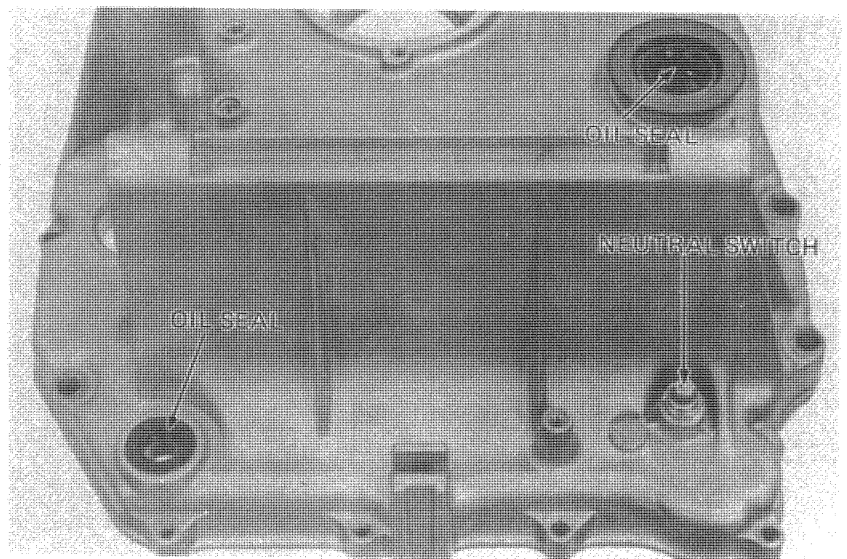



Install the A.C. generator stator and right and left fixed pulsers.

NOTE

- Install the pulsers with their holding tabs facing the timing inspection window.
- Route the wires properly.

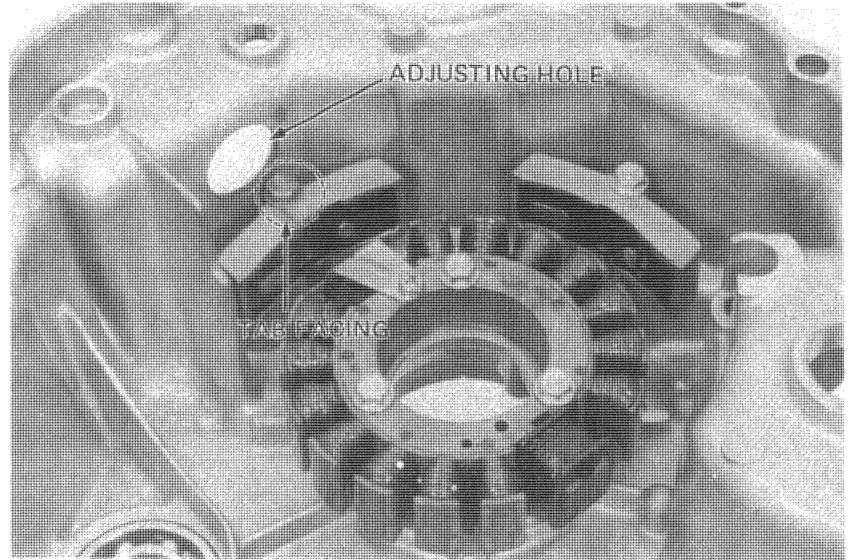

Install the C.D.I. pulser stator.

NOTE

- Align the marks on the rear cover and stator. If the marks are not aligned, ignition timing will be incorrect.
- Route the wires and cables properly.
- Replace the pulser rotor and stator as a set.

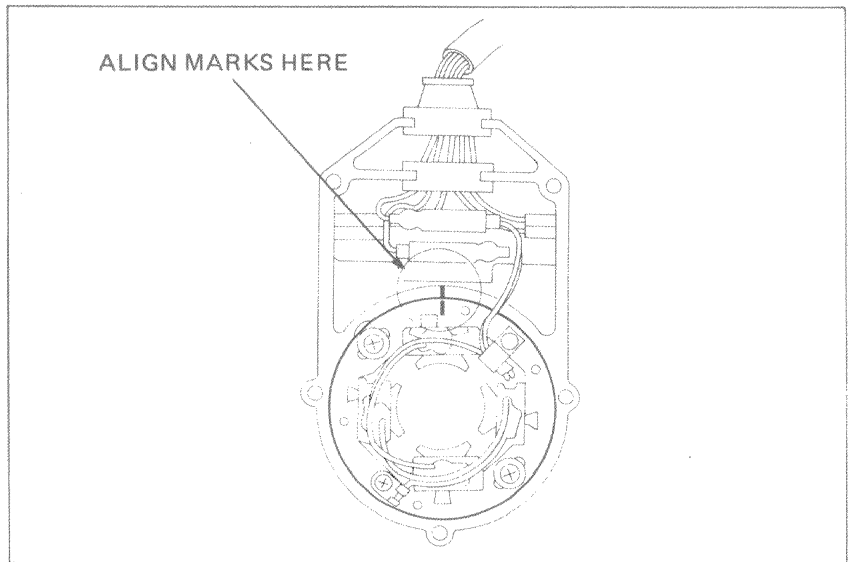

Install the C.D.I. pulser cover.
Connect the neutral switch wires, and secure with the neutral cord guide.
Install the mechanical seal (Page 9-6).

• **ASSEMBLY**

- Install the following parts:
REAR COVER (Page 9-7)
STARTER MOTOR (Page 9-7)
TRANSMISSION COVER (Page 7-13)
ENGINE (Section 5)

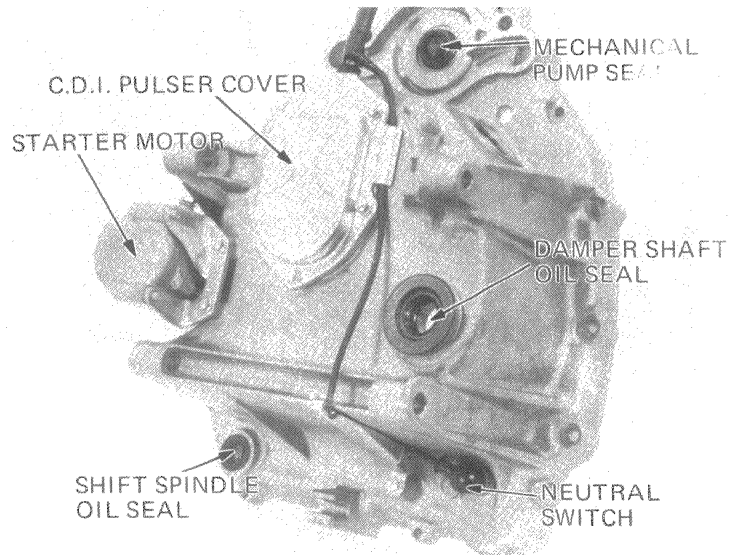



COOLING SYSTEM

