



SERVICE INFORMATION	16-1
TROUBLESHOOTING	16-2
BATTERY	16-3
CHARGING SYSTEM	16-4
A.C. GENERATOR REMOVAL/ INSTALLATION	16-6

SERVICE INFORMATION

• WORKING PRACTICE

Battery acid level should be checked regularly, add distilled water when necessary.
 Quick-charging the battery should only be done in an emergency; slow-charging is preferred.
 Remove the battery from the motorcycle for charging.
 Keep fire or sparks away from a charging battery because it produces hydrogen.
 All charging system components can be tested on the motorcycle.

• SPECIFICATIONS

Battery	Capacity	12V, 14 ampere-hours
	Specific gravity	1.28/20°C (68°F)
	Charging rate	1.4 amperes maximum
AC generator	Capacity	High beam: 5 amperes minimum/5,000 rpm (14.5 volts)
Voltage regulator	Type	Transistorized non-adjustable

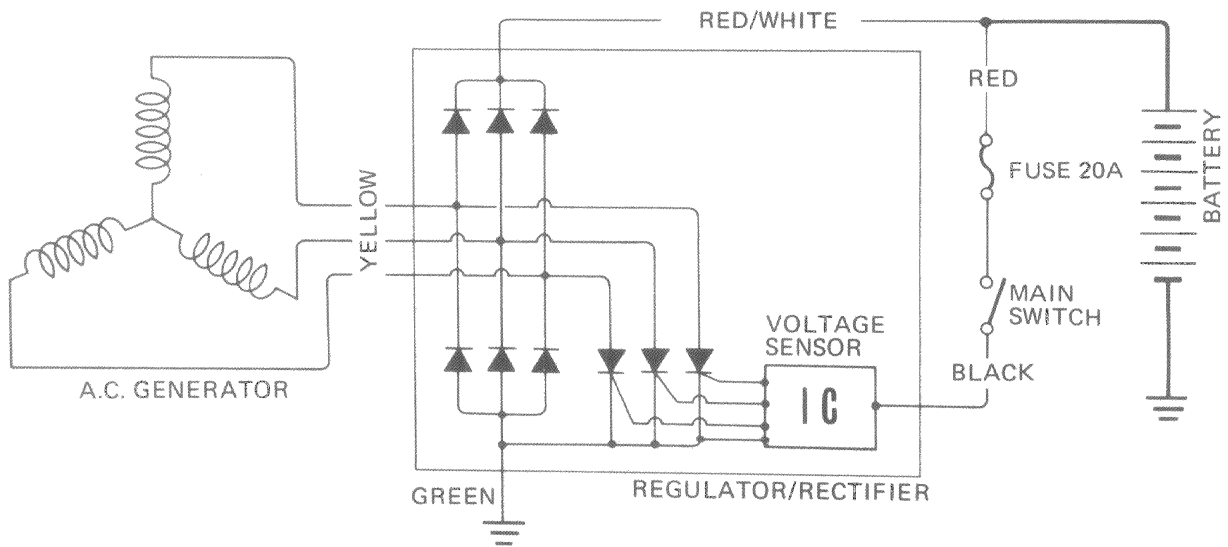

TROUBLESHOOTING

No Power — Key Turned On:

1. Dead battery
 - Battery not charged
 - Battery electrolyte evaporated
 - Battery specific gravity low
 - Charging system failure
2. Disconnected battery cable
3. Main fuse burned out
4. Faulty ignition switch

Low Power — Key Turned On:

1. Weak battery
 - Low battery electrolyte level
 - Battery specific gravity low
 - Charging system failure
2. Loose battery connection

Low Power — Engine Running

1. Battery undercharged
 - Low battery electrolyte level
 - One or more dead cells
2. Charging system failure

Intermittent Power:

1. Loose battery connection
2. Loose charging system connection
3. Loose starting system connection
4. Loose connection or short circuit in ignition system
5. Loose connection or short circuit in lighting system

Charging System Failure:

1. Loose, broken, or shorted wire or connection
2. Faulty voltage regulator
3. Faulty silicon rectifier
4. Faulty A.C. generator



BATTERY

● REMOVAL

Disconnect the ground cable.
 Remove the battery holder.
 Disconnect the positive (+) cable at the battery.
 Disconnect the battery breather tube, and remove the battery.

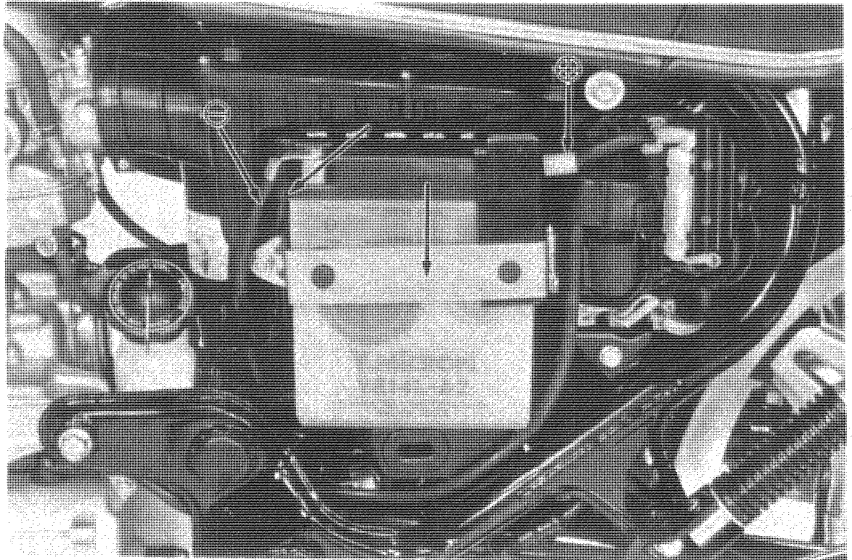

● TESTING SPECIFIC GRAVITY

Test each cell by drawing electrolyte into the hydrometer.

SPECIFIC GRAVITY (20°C, 68°F)

Fully charged: 1.27–1.29

Undercharged: Below 1.26

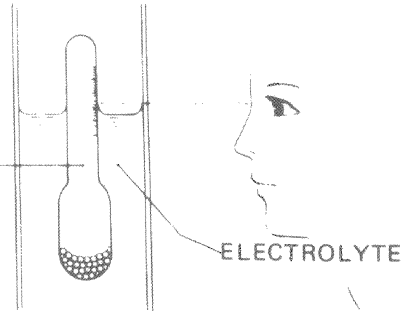

NOTE

- The battery must be recharged if the specific gravity is below 1.23.
- The specific gravity varies with the temperature as shown in the accompanying table.
- Replace the battery if sulfation is evident.
- The battery must be replaced if pastes have settled on the bottom of each cell.

WARNING

- *The battery electrolyte contains sulfuric acid. Protect your eyes, skin, and clothing.*
- *In case of contact, flush thoroughly with water and call a doctor if your eyes were exposed.*

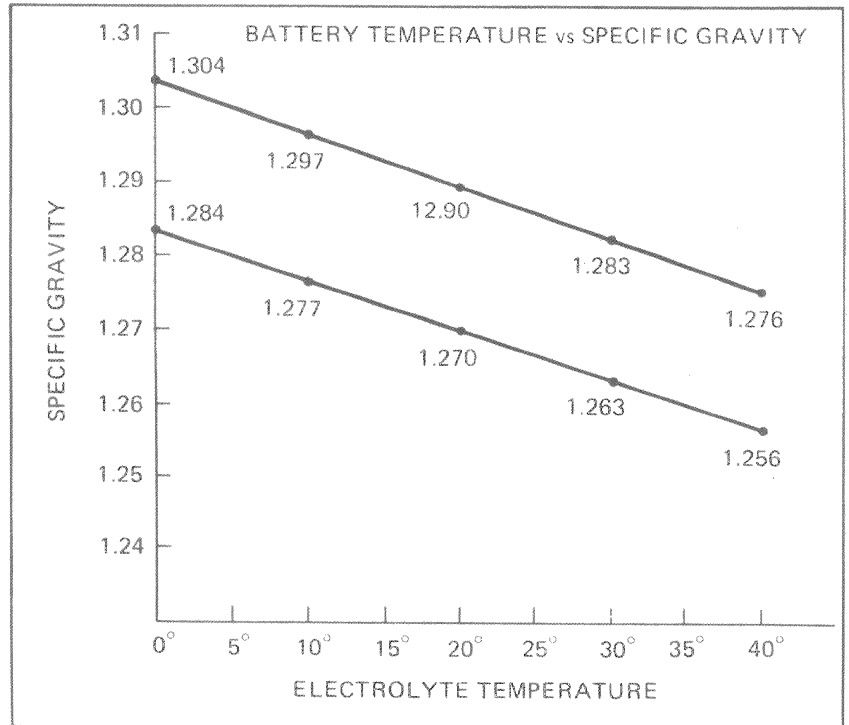

Specific gravity changes by 0.007 for every 10°C



BATTERY/CHARGING SYSTEM

• **BATTERY CHARGING**

Hookup instruction:

Connect the charger positive (+) cable to the battery positive (+) terminal.

Connect the charger negative (-) cable to the battery negative (-) terminal.

Charging current:

1.4 amperes maximum

Charging:

Charge the battery until specific gravity is 1.27 ~ 1.29 at 20°C (68°F)

WARNING

- Before charging a battery, remove the cap from each cell.
- Keep fire and sparks away from a charging battery.
- Turn power ON/OFF at the charger, not at the battery terminals.
- Discontinue charging if the electrolyte temperature exceeds 45°C (117°F).

CAUTION

Quick-charging should only be done in an emergency; slow-charging is preferred.

After installing the battery, apply an anti-corrosive coating to the terminals.

CAUTION

Route the breather tube as shown on the battery caution label.

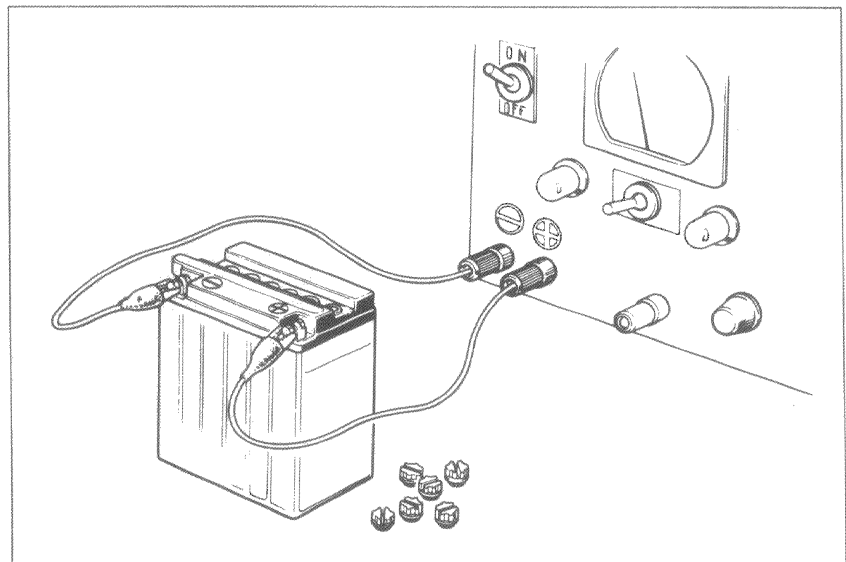

CAUTION

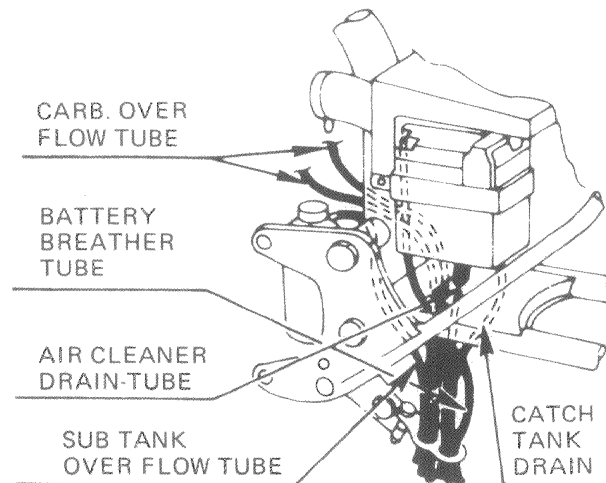

CHARGING SYSTEM

• **CHARGING OUTPUT TEST**

Warm up the engine before taking readings. Disconnect the black lead from the regulator/rectifier to bypass the voltage regulator. Connect a voltmeter and ammeter.

NOTE

Use a fully charged battery to check the charging system output.

TECHNICAL DATA:

MAIN SWITCH	LIGHT-ING SWITCH	CHARG-ING RPM	5,000 rpm
ON	ON (High beam)	1,100 rpm	(5 amperes minimum/ 14.5 volts)

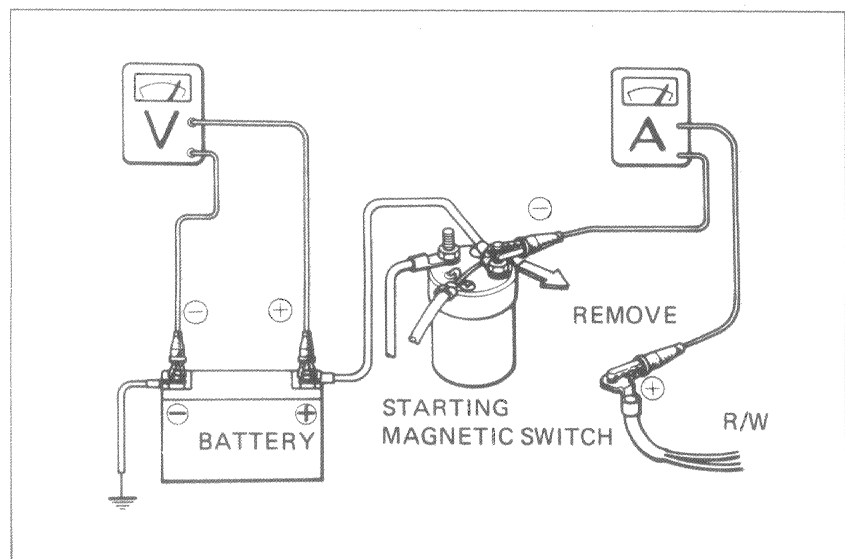



• STATOR COIL CONTINUITY TEST

NOTE

It is not necessary to remove the stator to make this test.

Check the yellow leads to the AC generator stator for continuity with each other. Replace the stator if any yellow lead is not continuous with the others, or if any lead has continuity to ground.

REMOVAL (Page 8-3)

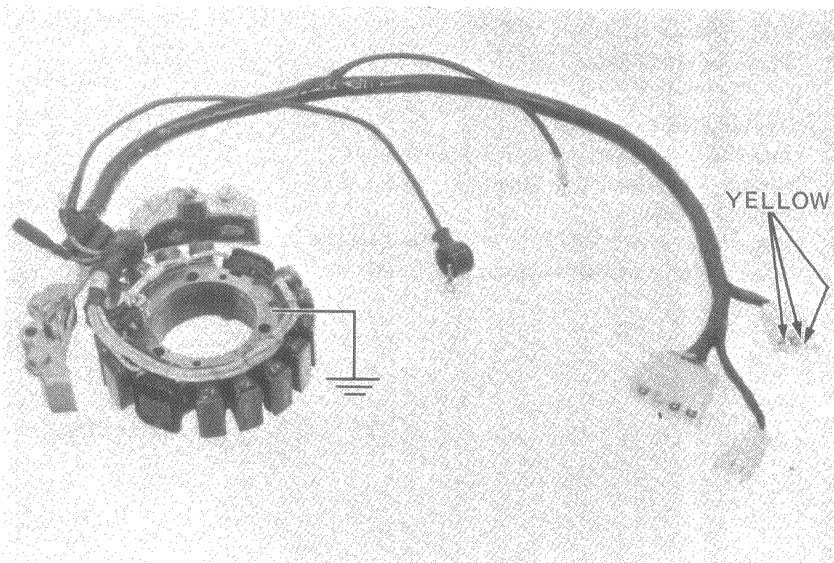

• VOLTAGE REGULATOR/RECTIFIER TEST

Check the resistances between the leads with an ohmmeter.

WARNING

Do not use a high voltage source such as insulation resistance tester since it may damage the rectifier and give you a shock.

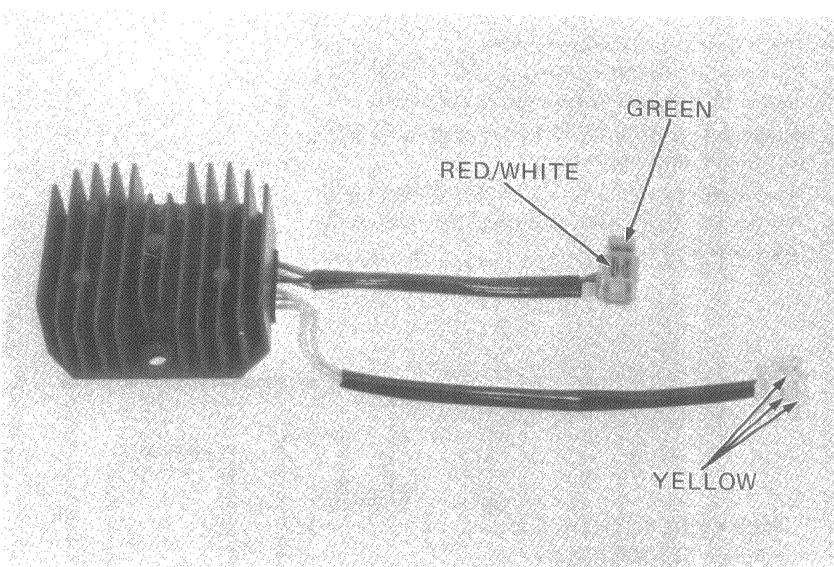

NORMAL DIRECTION: CONTINUITY

	⊕ probe	⊖ probe
I	YELLOW	GREEN
II	RED/WHITE	YELLOW

REVERSE DIRECTION: NO CONTINUITY

	⊕ probe	⊖ probe
I	GREEN	YELLOW
II	YELLOW	RED/WHITE

NOTE

The test results shown are for a positive ground ohmmeter and the opposite results will be obtained when a negative ground ohmmeter is used.

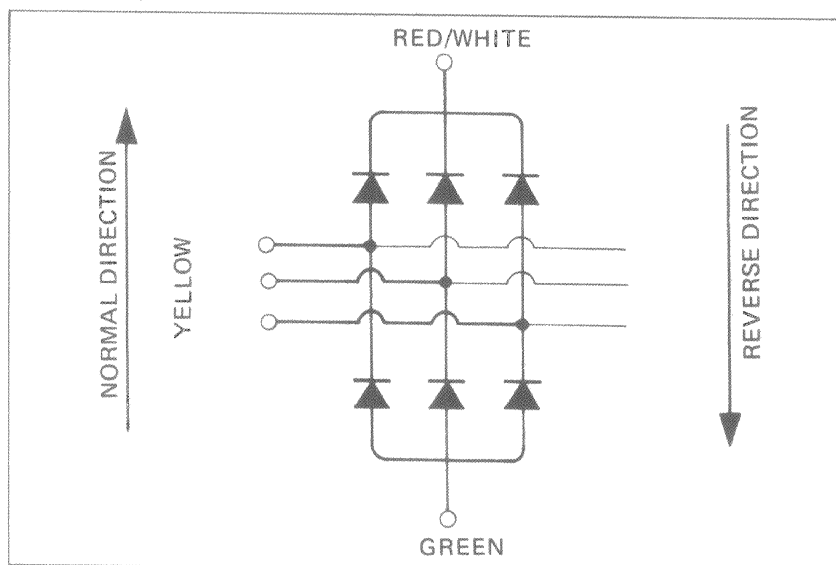



BATTERY/CHARGING SYSTEM

● **VOLTAGE REGULATOR PERFORMANCE TEST**

- a. Testing with a voltmeter
Connect a voltmeter across the battery.
Check regulator performance with the engine running.
Regulator must divert current to ground when battery voltage reaches 14.0 ~ 15.0 V.

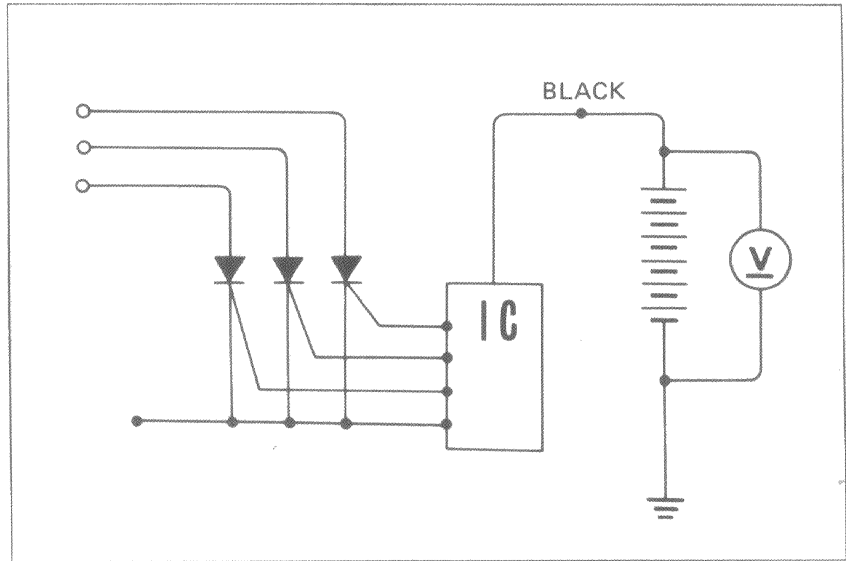

- b. Testing with a variable resistor
Connect a variable resistor (0 ~ 100 Ω) across the battery with a 50 Ω resistance.
Check for continuity between green and each of three yellow terminals.
Test lamp must come on when voltage reads 14 to 15 V on the voltmeter by adjusting the variable resistor.

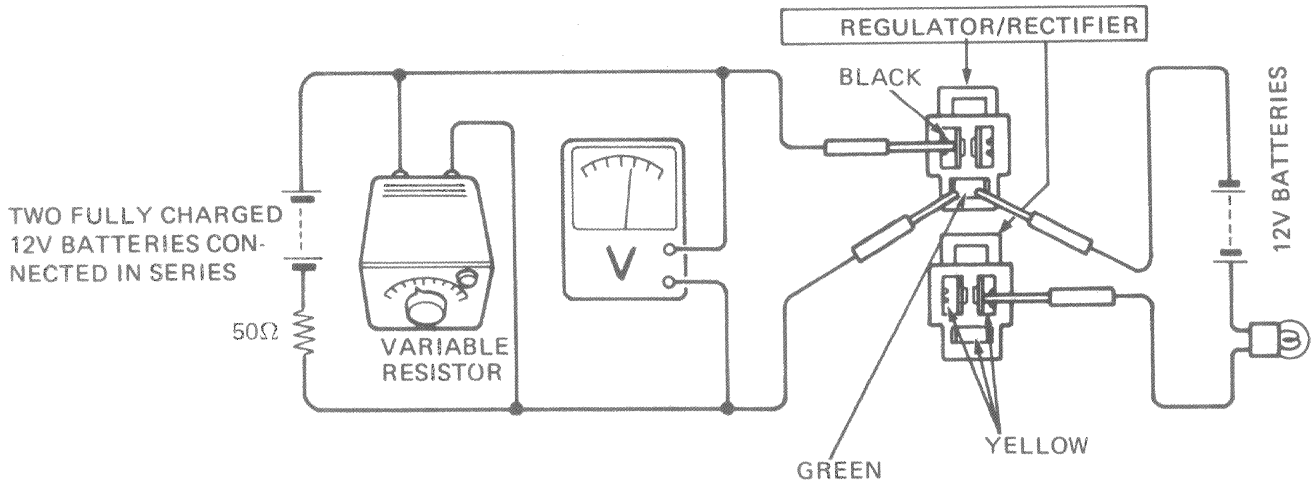

**A.C. GENERATOR REMOVAL/
INSTALLATION**

Removal and installation procedure Section 8.