



18. STARTER MOTOR

SERVICE INFORMATION	18-1
TROUBLESHOOTING	18-2
STARTER MOTOR	18-3
MAGNETIC SWITCH	18-5
DIODE	18-5
NEUTRAL SWITCH	18-5 (8-3)
STARTER CLUTCH	18-5 (8-5)

SERVICE INFORMATION

• WORKING PRACTICE

The starter motor can be removed with the engine in the frame. Starter clutch repairs (Page 8-3).

• SPECIFICATIONS

		STANDARD	SERVICE LIMIT
Starter motor	Brush spring tension	0.495-0.605 kg	400 g
	Brush length	11.0-12.5 mm (0.43-0.49 in.)	5.5 mm (0.21 in.)

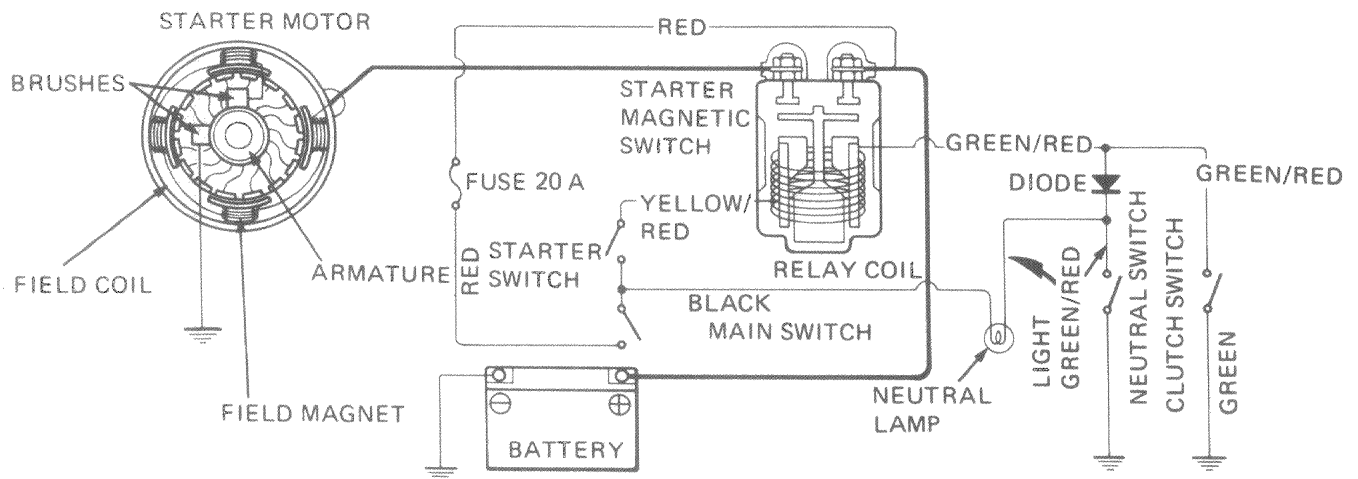



STARTER MOTOR

TROUBLESHOOTING

Starter Motor Will Not Turn:

1. Dead battery
2. Faulty ignition switch
3. Faulty start switch
4. Faulty neutral switch
5. Faulty starter magnetic switch
6. Loose or disconnected wire or cable
7. Neutral diode open
8. Faulty clutch switch

Starter Motor Turns Engine Slowly:

1. Low battery
2. Excessive resistance in circuit
3. Binding in starter motor

Starter Motor Turns, But Engine Does Not Turn:

1. Faulty starter clutch
2. Faulty starter motor gears
3. Faulty starter motor or idle gear

Starter Motor and Engine Turn, But Engine

Does Not Start:

1. Faulty ignition system
2. Engine problems
3. Faulty engine stop switch



STARTER MOTOR

• REMOVAL

WARNING

With the ignition switch OFF, remove the negative cable at the battery before servicing the starter motor.

Remove the starter mounting bolts and pull the motor out of the engine case. Disconnect the starter cable.

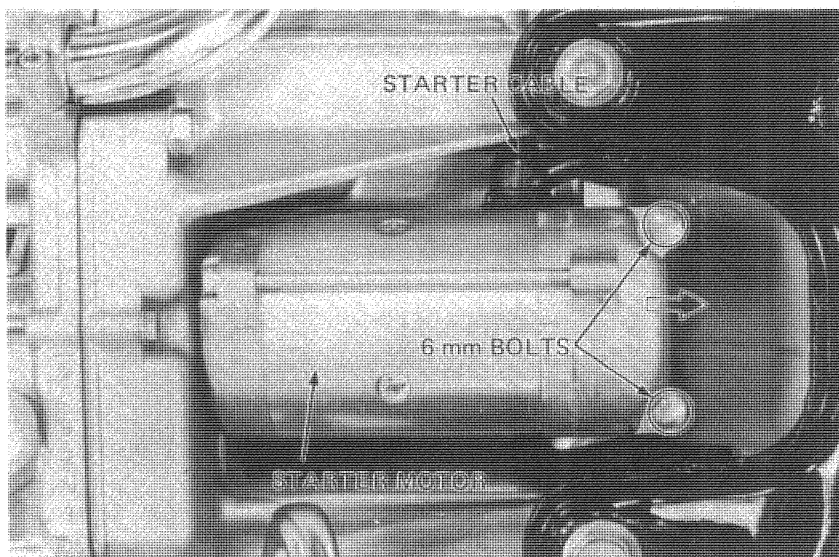

• BRUSH INSPECTION

Remove the starter motor case screws. Inspect the brushes and measure brush length. Measure brush spring tension with a spring scale.

SERVICE LIMITS:

Brush length: 5.5 mm (0.21 in.)

Brush spring tension: 400 g

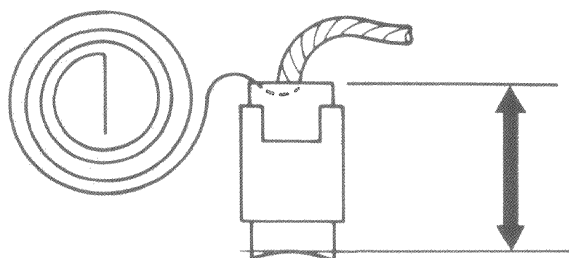

• COMMUTATOR INSPECTION

Remove the case.

NOTE

Record the location and number of the thrust washers.

Inspect the commutator bars for discoloration.

Bars discolored in pairs indicate grounded armature coils.

NOTE

Do not use emery or sand paper on the commutator.

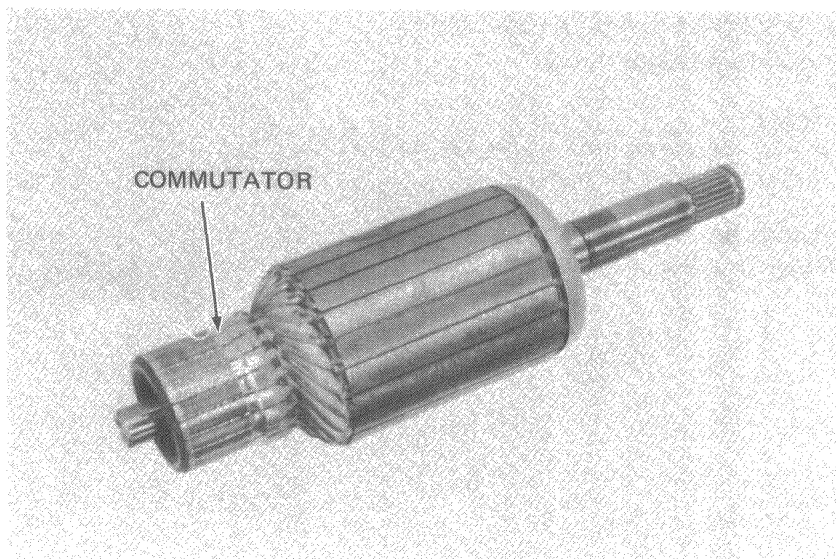



STARTER MOTOR

Check for continuity between pairs of commutator bars, and also between commutator bars and armature shaft.

Replace starter motor if armature coils are open, or shorted to armature shaft.

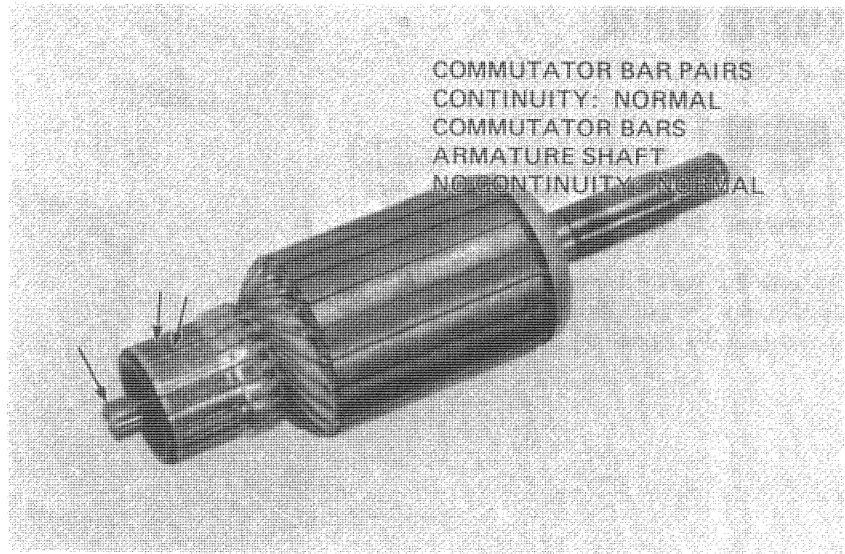

● **FIELD COIL INSPECTION**

Check for continuity from the cable terminal to the motor case and from the cable terminal to the brush wire.

Replace the starter motor if the field coil is not continuous or if it is shorted to the motor case.

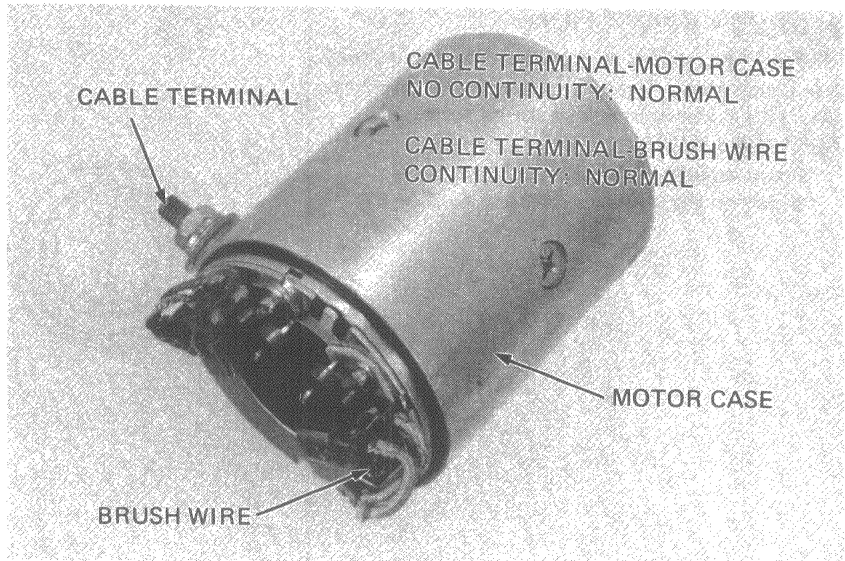

● **ASSEMBLY/INSTALLATION**

Assemble the starter motor.

NOTE

Align the punch mark on the case to the punch mark on the cover.

Connect the starter motor cable.
Install the starter motor on the engine.

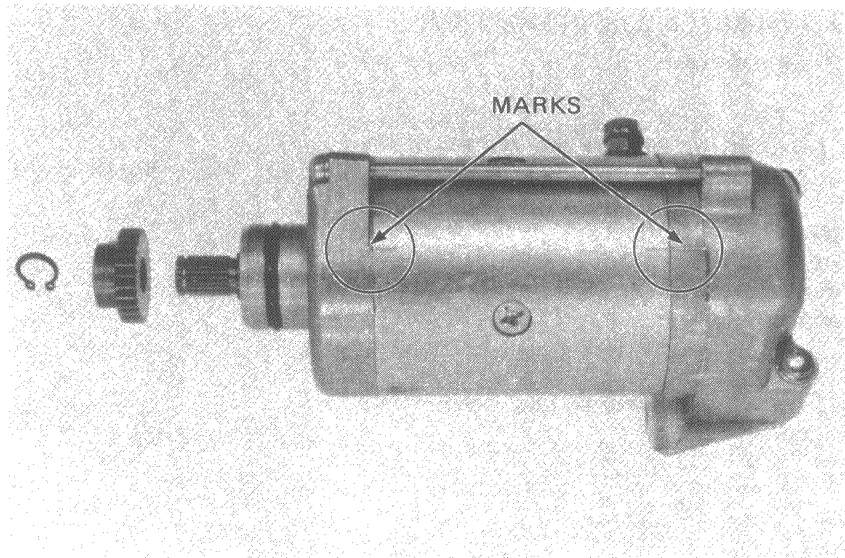



MAGNETIC SWITCH

• INSPECTION

To test if the switch primary coil is normal, depress the switch button. The coil is normal if the switch clicks into position.

Connect an ohmmeter to the switch terminals. Connect a 12 V battery to the switch cable terminals.

The switch is normal if there is continuity.

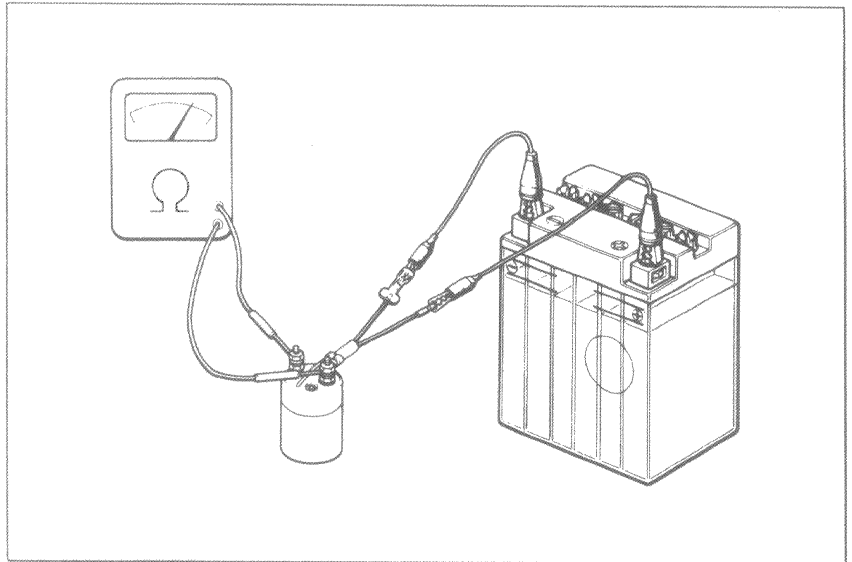

DIODE

• INSPECTION

Remove the fuse cover.

Connect an ohmmeter to the diode leads.

NORMAL DIRECTION: CONTINUITY

⊕ probe : Light green/Red

⊖ probe : Green/Red

REVERSE DIRECTION: NO CONTINUITY

⊕ probe : Green/Red

⊖ probe : Light green/Red

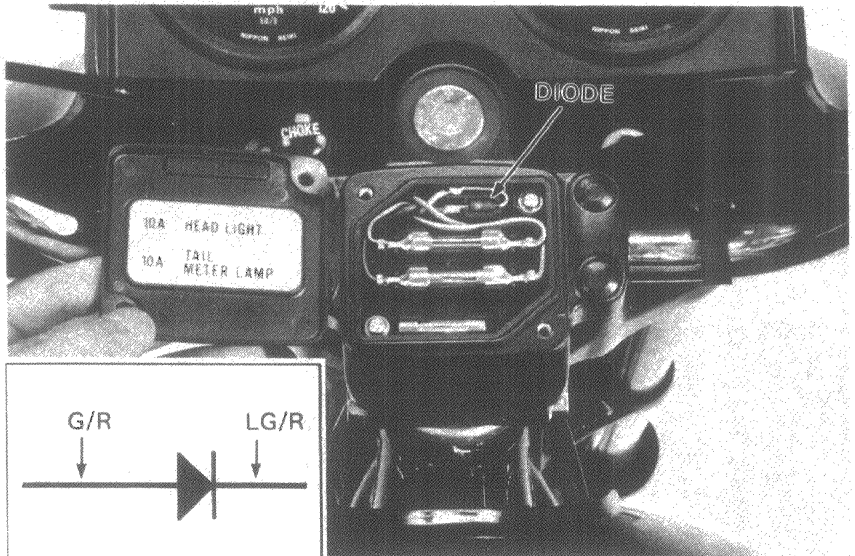

NEUTRAL SWITCH

• INSPECTION (Page 8-3)

STARTER CLUTCH

• REMOVAL (Page 8-5)



**WATER COOLED
V-TWIN ENGINE**

