



## INTRODUCTION

This Addendum contains information for the 1979 CX500 DELUXE and CUSTOM models.

Refer to the base Shop Manual and the previous Addendum for service procedures and data not included in this addendum.

ALL INFORMATION, ILLUSTRATIONS, DIRECTIONS AND SPECIFICATIONS INCLUDED IN THIS PUBLICATION ARE BASED ON THE LATEST PRODUCT INFORMATION AVAILABLE AT THE TIME OF APPROVAL FOR PRINTING. HONDA MOTOR CO., LTD. RESERVES THE RIGHT TO MAKE CHANGES AT ANY TIME WITHOUT NOTICE AND WITHOUT INCURRING ANY OBLIGATION WHATEVER.

NO PART OF THIS PUBLICATION MAY BE REPRODUCED WITHOUT WRITTEN PERMISSION.

HONDA MOTOR CO., LTD.  
Service Publications Office

## TABLE OF CONTENTS

MODEL IDENTIFICATION .....	22- 2
SPECIFICATIONS .....	22- 3
WIRING DIAGRAM .....	22- 5
CABLE & HARNESS ROUTING .....	22- 6
RADIATOR COVER .....	22- 9
SEAT & FUEL TANK .....	22- 9
HEADLIGHT .....	22-10
INSTRUMENTS .....	22-11
REAR SHOCK ABSORBER .....	22-13
OIL PRESSURE/STOP LAMP WARNING INDICATOR .....	22-14



**MODEL IDENTIFICATION**

DELUXE

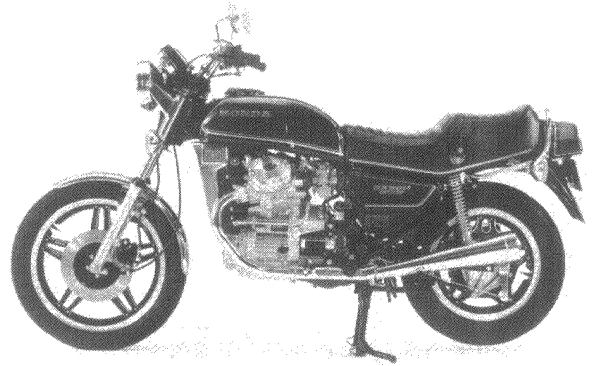
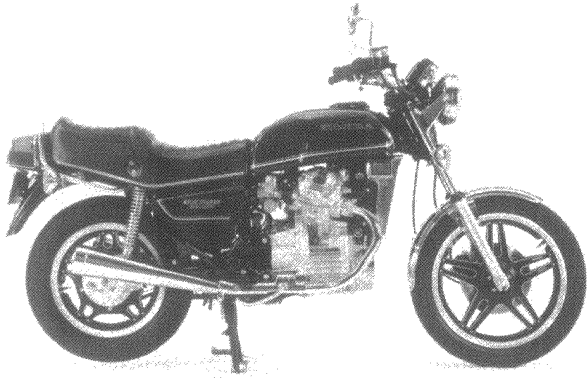

CUSTOM

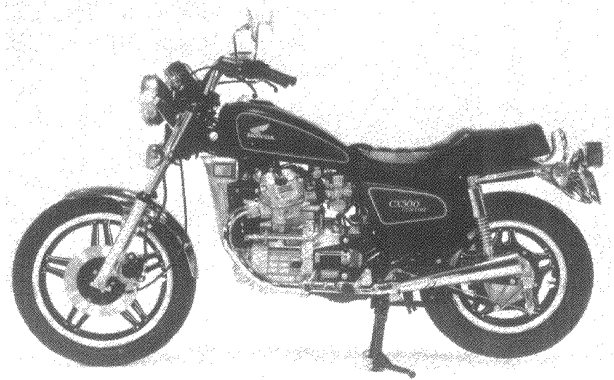
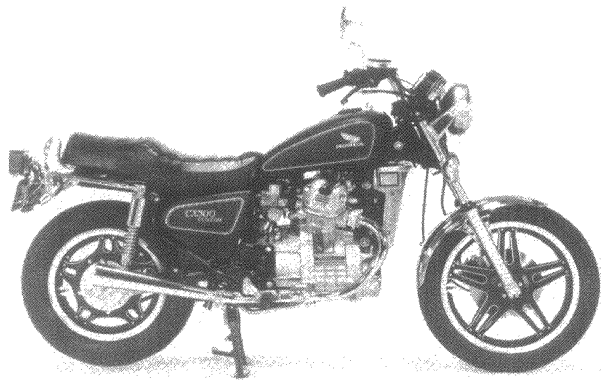



**SPECIFICATIONS**

ITEM			SPECIFICATIONS		
			DELUXE	CUSTOM	
DIMENSIONS	Overall length		2,185 mm (86.0 in)		
	Overall width		865 mm (34.1 in)		
	Overall height		1,165 mm (45.9 in)		
	Wheelbase		1,455 mm (57.3 in)		
	Seat height		800 mm (31.5 in)		
	Foot peg height		335 mm (13.2 in)		
	Ground clearance		145 mm ( 5.7 in)		
	Dry weight		205 kg (452 lb)		
FRAME	Type		Diamond		
	Front suspension, travel		Telescopic fork, 139.5 mm (5.5 in)		
	Rear suspension, travel		Swingarm, 85 mm (3.3 in)		
	Front tire size		3.50S19-4PR		
	Rear tire size		130/90-16 67S		
	Cold tire pressures	Up to 90 kg (200 lbs) load	Front	2.0 kg/cm <sup>2</sup> (28 psi)	
			Rear	2.0 kg/cm <sup>2</sup> (28 psi)	
		Up to vehicle capacity load	Front	2.0 kg/cm <sup>2</sup> (28 psi)	
			Rear	2.25 kg/cm <sup>2</sup> (32 psi)	
	Front brake, lining swept area		Disc brake, 601 cm <sup>2</sup> (93.2 sq in)		
Rear brake, lining swept area		Internal expanding shoes, 201 cm <sup>2</sup> (31.2 sq in)			
Fuel capacity		17 liters (4.5 US gal)		11 liters (2.9 US gal)	
		3.5 liters (0.9 US gal)		2.5 liters (0.7 US gal)	
Caster angle		63° 15'			
Trail		105 mm (4.1 in)			
Front fork oil capacity		135 cc (4.6 ozs) After assembly			
ENGINE	Type		Liquid cooled 4-stroke OHV		
	Cylinder arrangement		2 cylinder transverse V		
	Bore and stroke		78 x 52 mm (3.071 x 2.047 in)		
	Displacement		496 cc (30.3 cu in)		
	Compression ratio		10:1		
	Valve train		Silent chain driven camshaft and push rod		
	Oil capacity		3.0 liters (3.2 US qt) After draining		
	Lubrication system		Forced pressure and wet sump		
	Cooling system capacity		2.0 liters (0.52 US gal)		
	Air filtration		Paper filter		
	Cylinder compression		12 kg/cm <sup>2</sup> (171 psi)		
	Intake valve	Opens	6° BTDC (at 1 mm lift), 75° BTDC (at 0 lift)		
		Closes	46° ABDC (at 1 mm lift), 115° ABDC (at 0 lift)		
	Exhaust valve	Opens	46° BBDC (at 1 mm lift), 111° BBDC (at 0 lift)		
		Closes	6° ATDC (at 1 mm lift), 71° ATDC (at 0 lift)		
Valve clearance		IN: 0.08 mm (0.003 in)		EX: 0.10 mm (0.004 in)	
Engine weight		65 kg (143 lb)			
Idle speed		1,100 ± 100 rpm			



ITEM		SPECIFICATIONS																						
		DELUXE			CUSTOM																			
CARBURETION	Carburetor type	CV 35 mm (1.4 in)																						
	Identification number	VB23A			VB27A																			
	Pilot screw Float level	See page 4-10 15.5 mm (0.61 in)																						
DRIVE TRAIN	Clutch Transmission Primary reduction Gear ratio I Gear ratio II Gear ratio III Gear ratio IV Gear ratio V Final reduction Gear shift pattern	Wet, multi-plate 5-speed, constant-mesh 2.242 2.733 1.850 1.416 1.148 0.931 3.091 (11/34) Left foot operated return system 1-N-2-3-4-5																						
ELECTRICAL	Ignition Ignition timing "F" mark Full advance RPM from "F" to full advance Starting system Generator Battery capacity Spark plug	CDI 15° BTDC 37° ± 3° BTDC 1,750-6,000 rpm Starting motor only Three phase A.C. generator 170 w/5,000 rpm 12V-14AH USA model																						
	Spark plug gap Fuse	<table border="1"> <thead> <tr> <th colspan="2">For cold climate below 5°C (41° F)</th> <th colspan="2">Standard</th> <th colspan="2">For extended high speed riding</th> </tr> <tr> <th>ND</th> <th>NGK</th> <th>ND</th> <th>NGK</th> <th>ND</th> <th>NGK</th> </tr> </thead> <tbody> <tr> <td>X22ES-U</td> <td>D7EA</td> <td>X24ES-U</td> <td>D8EA</td> <td>X27ES-U</td> <td>D9EA</td> </tr> </tbody> </table> Canadian model ND X24ESR-U, NGK DR8ES-L 0.6-0.7 mm (0.024-0.028 in) 20A (main), 10A (sub)						For cold climate below 5°C (41° F)		Standard		For extended high speed riding		ND	NGK	ND	NGK	ND	NGK	X22ES-U	D7EA	X24ES-U	D8EA	X27ES-U
For cold climate below 5°C (41° F)		Standard		For extended high speed riding																				
ND	NGK	ND	NGK	ND	NGK																			
X22ES-U	D7EA	X24ES-U	D8EA	X27ES-U	D9EA																			
LIGHTS	Headlight (high/low beam) Tail/stoplight Turn signal light (front/rear) Speedometer light Tachometer light Neutral indicator light Turn signal indicator light High beam indicator light Running light	65/50W sealed beam 8/27W (3/32 cp SAE NO. 1157) 23/23W (32/32 cp SAE NO. F. 1034, R. 1073) 3.4W (2 cp SAE NO. 57) 3.4W (2 cp SAE NO. 57) 3.4W (2 cp SAE NO. 57) 3.4W (2 cp SAE NO. 57) 3.4W (2 cp SAE NO. 57) 3.4W (2 cp SAE NO. 57) 8W (3 cp SAE NO. 1034)																						



WIRING DIAGRAM (CX500 DELUXE AND CUSTOM)

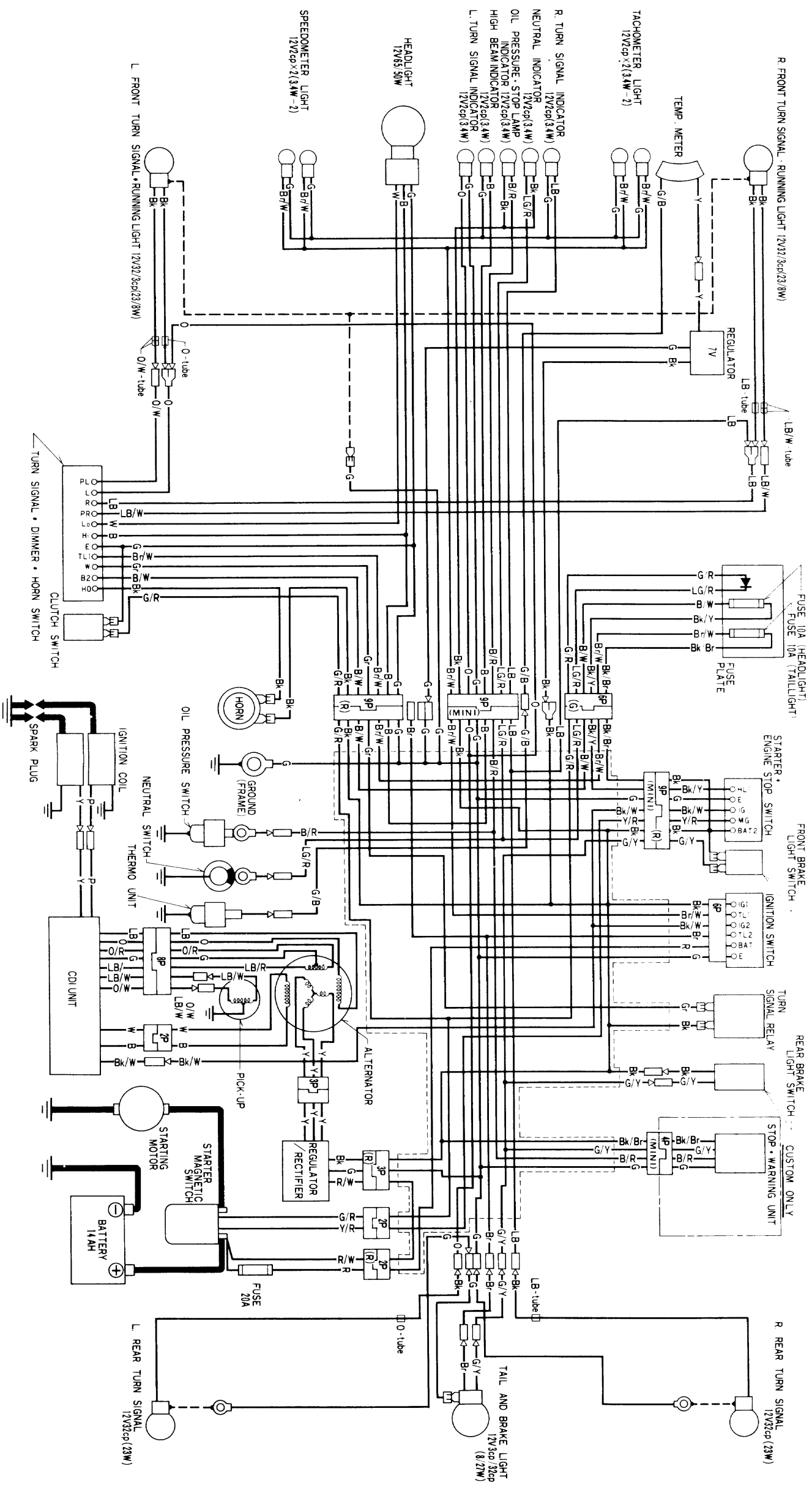

IGNITION SWITCH CONTINUITY

	E	IG2	BAT	IG1	TL1	TL2
OFF	○	○	○	○	○	○
ON	○	○	○	○	○	○
P	○	○	○	○	○	○
LOCK	○	○	○	○	○	○

STARTER + ENGINE STOP SWITCH CONTINUITY

	IG	E	STARTER SWITCH	MG	BAT2	HL1
OFF	○	○	○	○	○	○
FREE	○	○	○	○	○	○
PUSH	○	○	○	○	○	○
RUN	○	○	○	○	○	○
OFF	○	○	○	○	○	○

TURN SIGNAL + DIMMER SWITCH CONTINUITY

	B2	L0	H1	H0	E	TURN SIGNAL SWITCH	TURN SIGNAL SWITCH
Lo	○	○	○	○	○	○	○
(N)	○	○	○	○	○	○	○
H1	○	○	○	○	○	○	○
Lo	○	○	○	○	○	○	○
B2	○	○	○	○	○	○	○

Color Code Legend

B	Brown	Y	Yellow
Bk	Black	B	Blue
W	White	Gr	Grey
LG	Light Green	LB	Light Blue
R	Red	O	Orange
G	Green	P	Pink

0030Z-449-6700



CABLE & HARNESS ROUTING

DELUXE

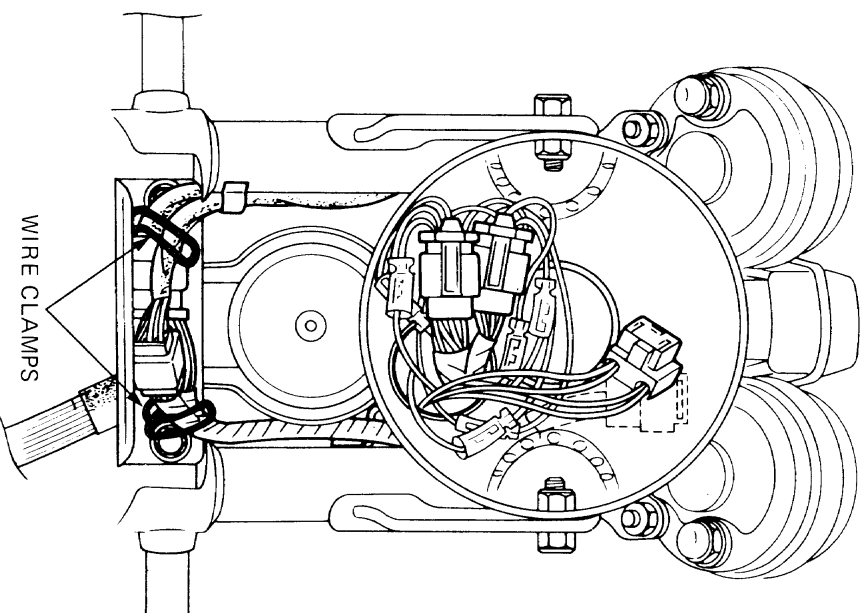
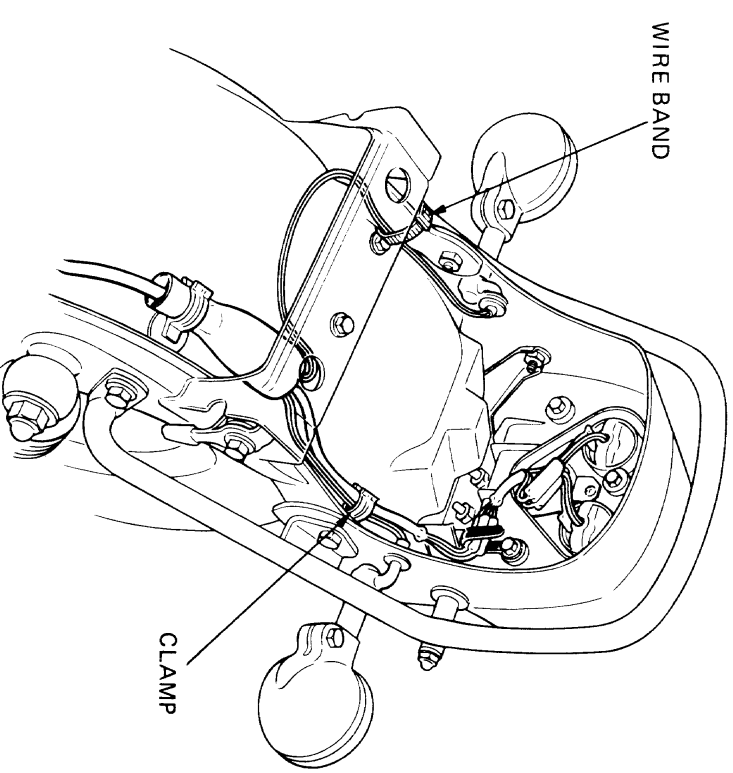
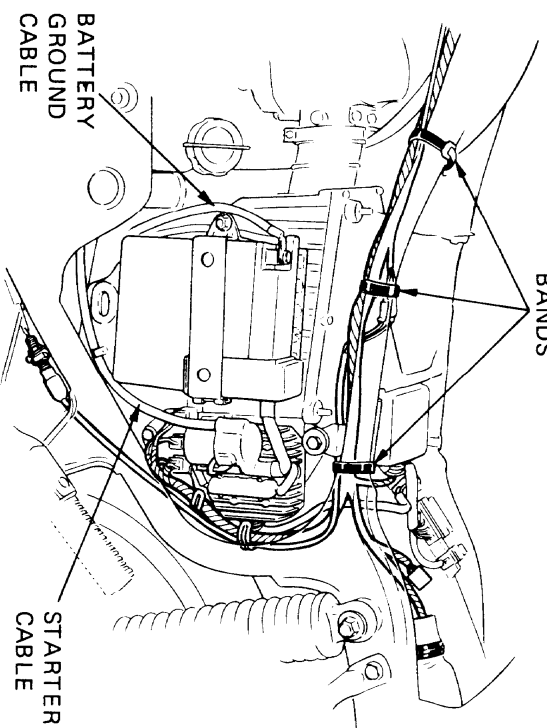
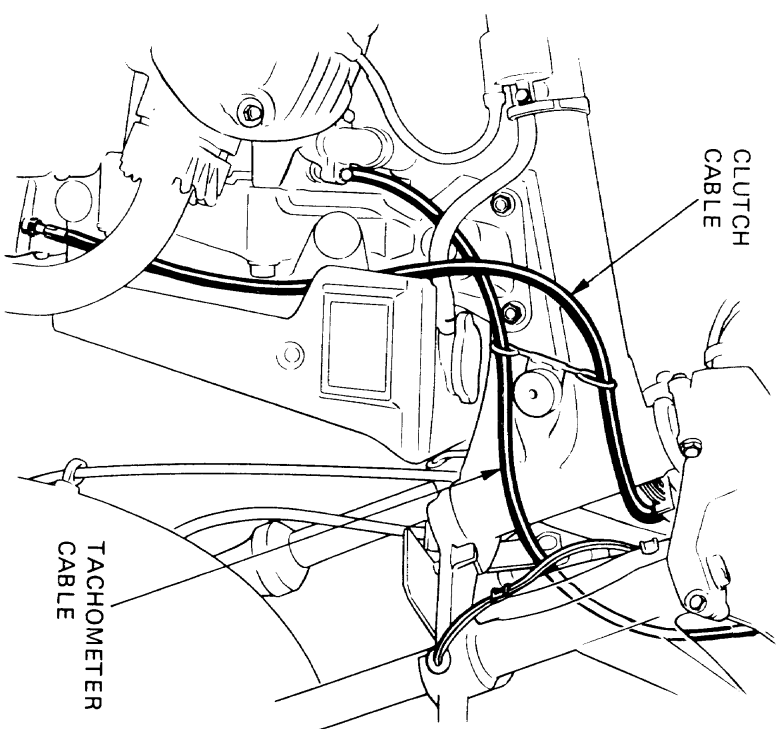
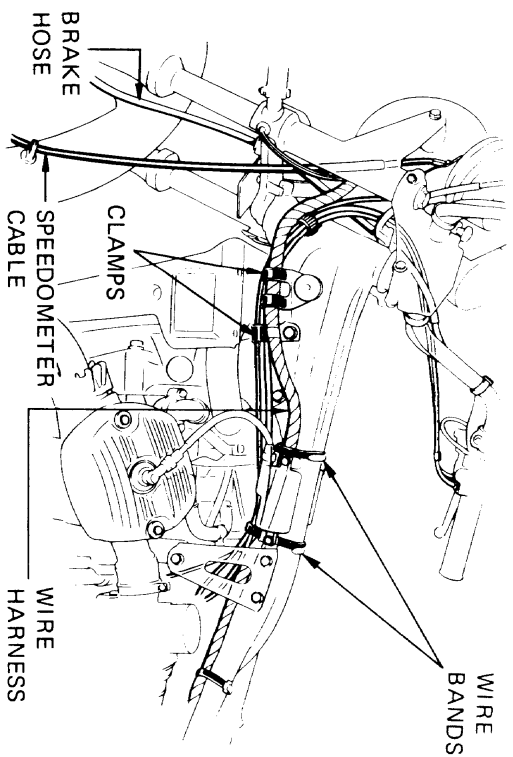
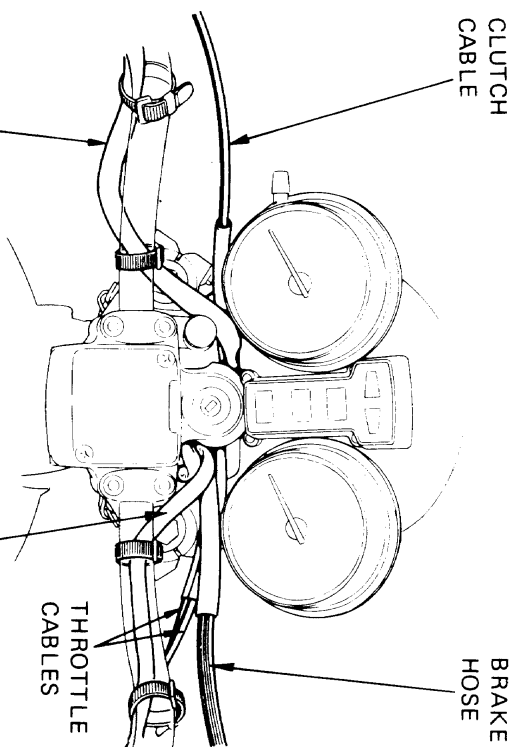



CUSTOM

CLUTCH  
CABLE

BRAKE HOSE

LEFT HANDLEBAR  
SWITCH WIRE HARNESS

RIGHT HANDLEBAR  
SWITCH WIRE HARNESS

THROTTLE  
CABLES

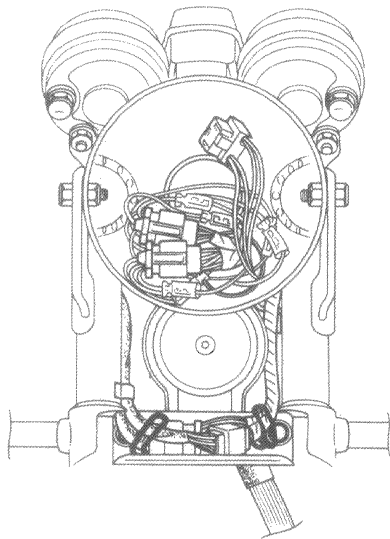

CLUTCH  
CABLE

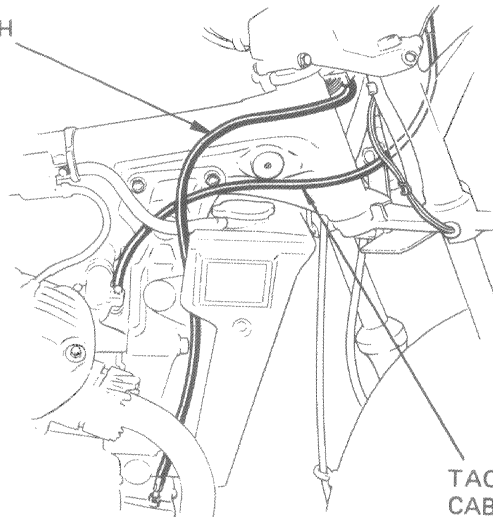

TACHOMETER  
CABLE

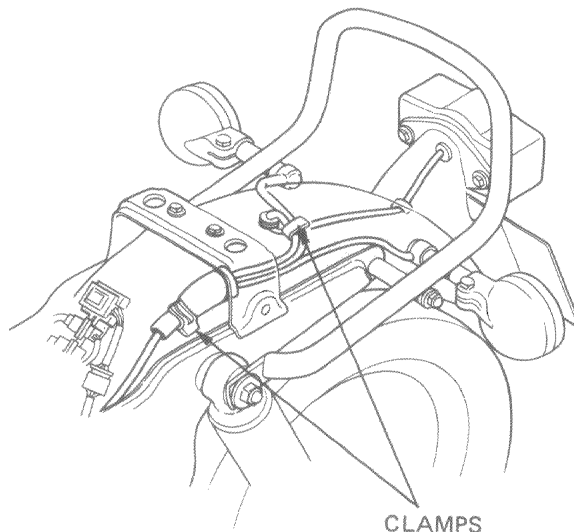

CLAMPS

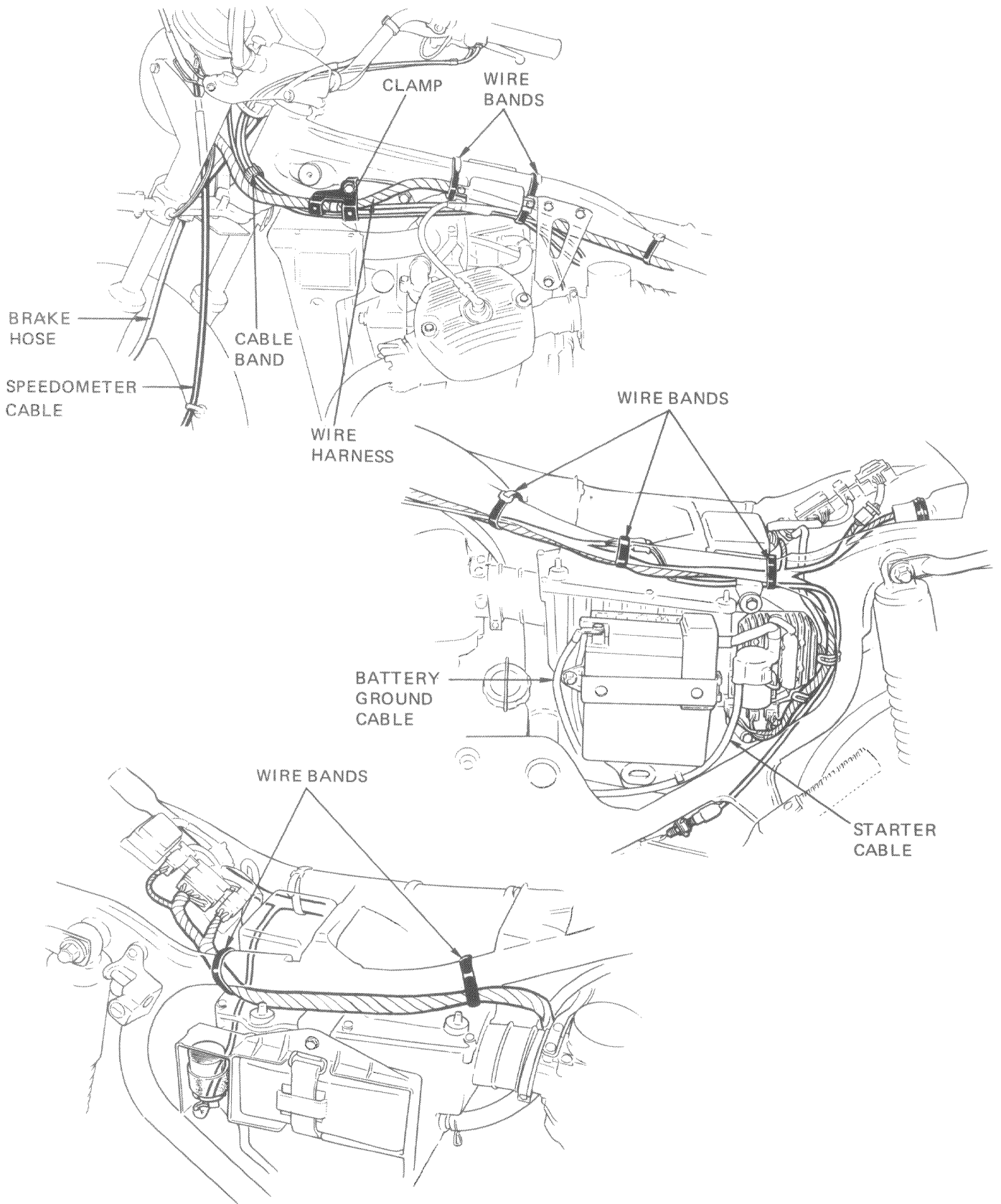





## RADIATOR COVER

### • REMOVAL

Remove the radiator cover mounting screws and the right and left covers. Remove the radiator grill.

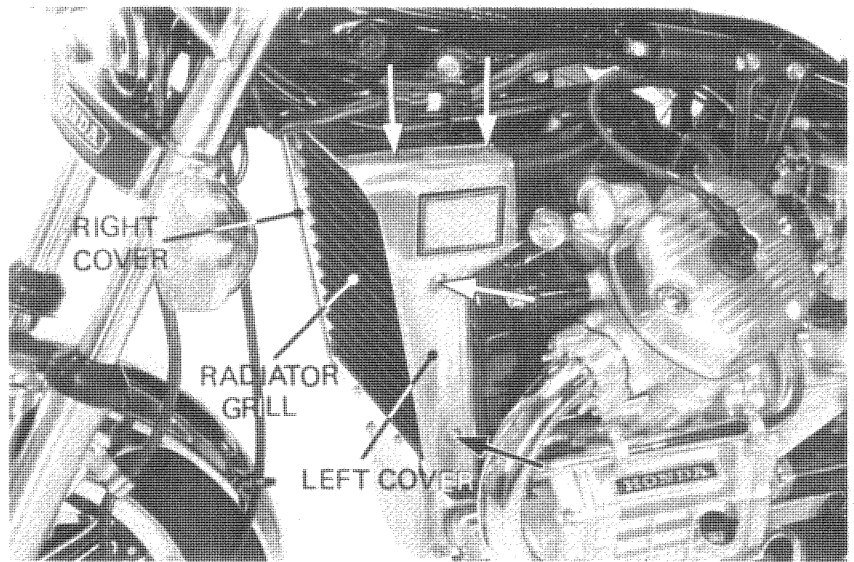

## CUSTOM : SEAT AND FUEL TANK

### • REMOVAL

Remove the two seat mounting bolts and the seat.

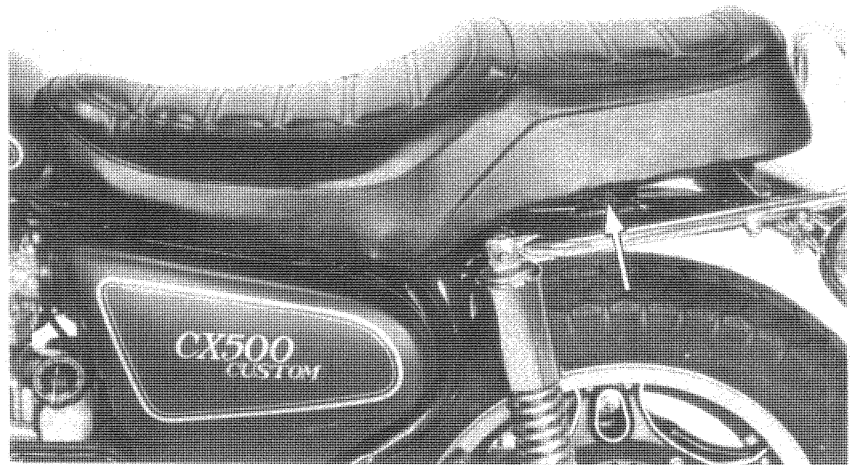

Turn the fuel valve OFF and disconnect the fuel line at the fuel valve.

Remove the three fuel tank mounting bolts and the fuel tank.





## HEADLIGHT

### • HEADLIGHT CASE REMOVAL

Remove the headlight.  
Disconnect all wires at their couplers and connectors.  
Unscrew the headlight case mounts and remove the case.

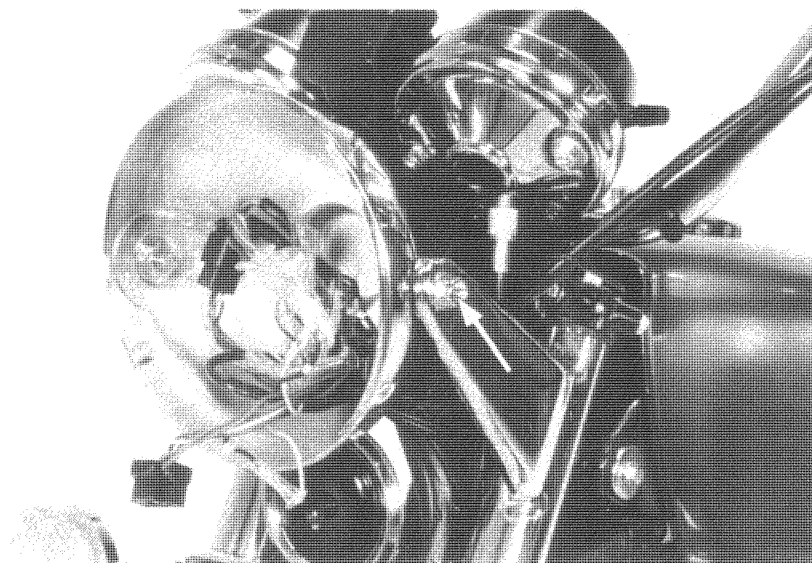

### • HEADLIGHT DISASSEMBLY/ ASSEMBLY

Remove the retaining screws and horizontal adjusting screw from the rim.  
Remove the two headlight unit retaining screws, and headlight unit.  
Assembly is the reverse of disassembly.

ADJUSTING  
SCREW

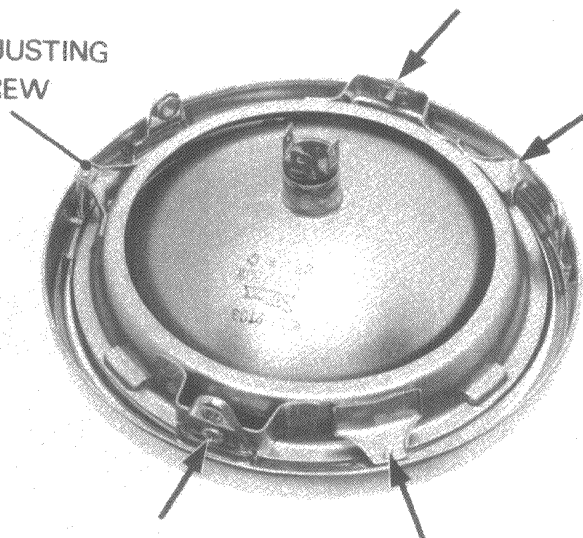

### • HEADLIGHT CASE INSTALLATION

Align the punch marks on the headlight case and bracket.  
Connect all wires at their couplers and connectors.

#### NOTE

Check each component for operation after assembling.

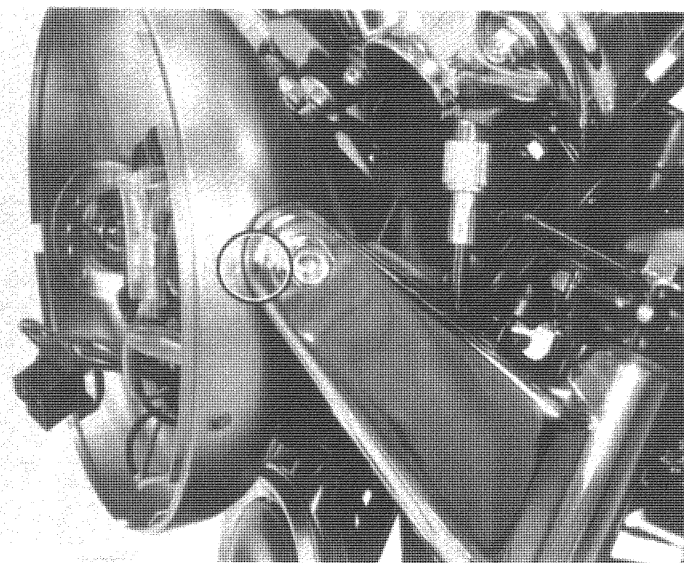



Connect the headlight coupler.  
Align the headlight thread holes with the headlight case holes.  
Secure the headlight with three screws.

### • HEADLIGHT AIM ADJUSTMENT

Vertical adjustment is made by loosening both headlight case mounting bolts.  
Adjust horizontally by turning the adjusting screw on the headlight rim.  
Turn the adjusting screw counterclockwise to direct the beam toward the right side of the rider.

#### NOTE

Adjust the headlight beam as specified by local and state laws.

#### WARNING

*An improperly adjusted headlight may blind oncoming drivers, or it may fail to light the road for a safe distance.*

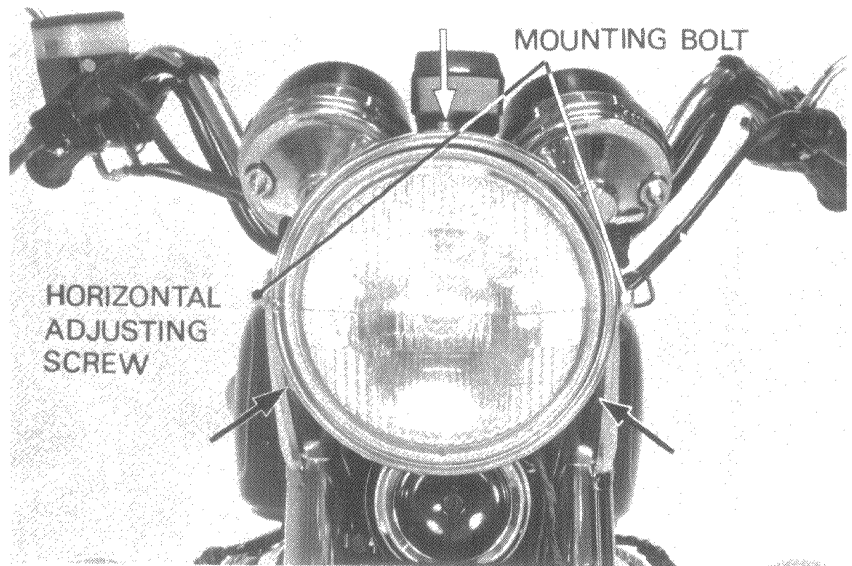

## INSTRUMENTS

### • INDICATOR BULB REPLACEMENT

Remove the indicator light panel screws and panel.  
Replace the bulb.  
If the replacement bulb does not light, check for loose connections, a short or open circuit.

### • METER ILLUMINATION BULB REPLACEMENT

Disconnect the meter cable.  
Remove the meter mounting nuts and meter.  
Remove the bulb socket.  
Replace the bulb.

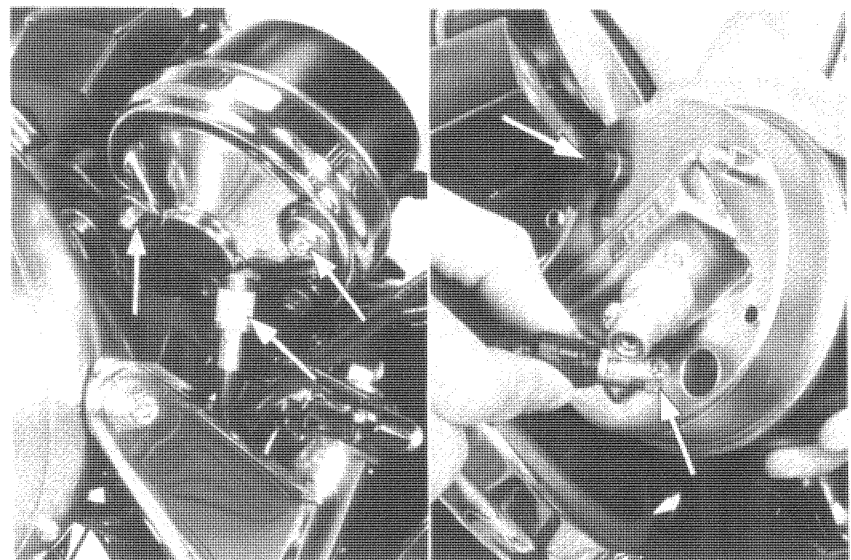
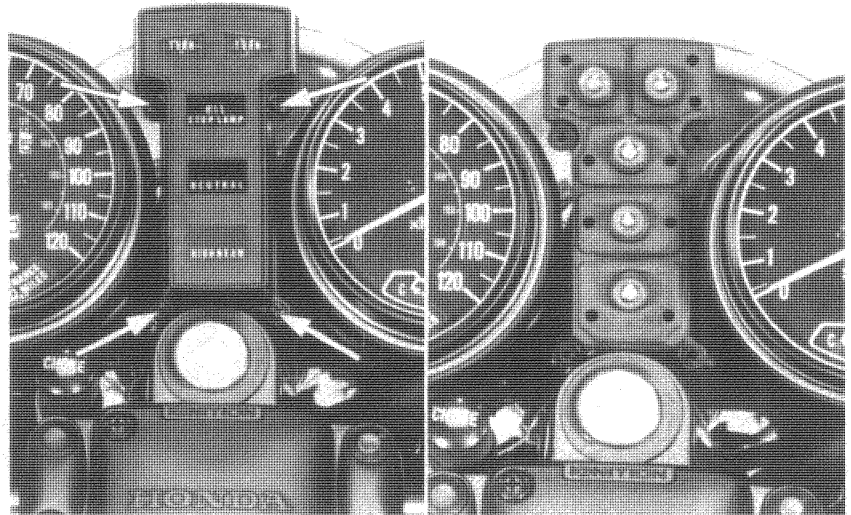



● INSTRUMENT REMOVAL

Remove the headlight.  
Disconnect the instrument wire connectors and coupler.  
Remove the speedometer and tachometer cables from the instruments.

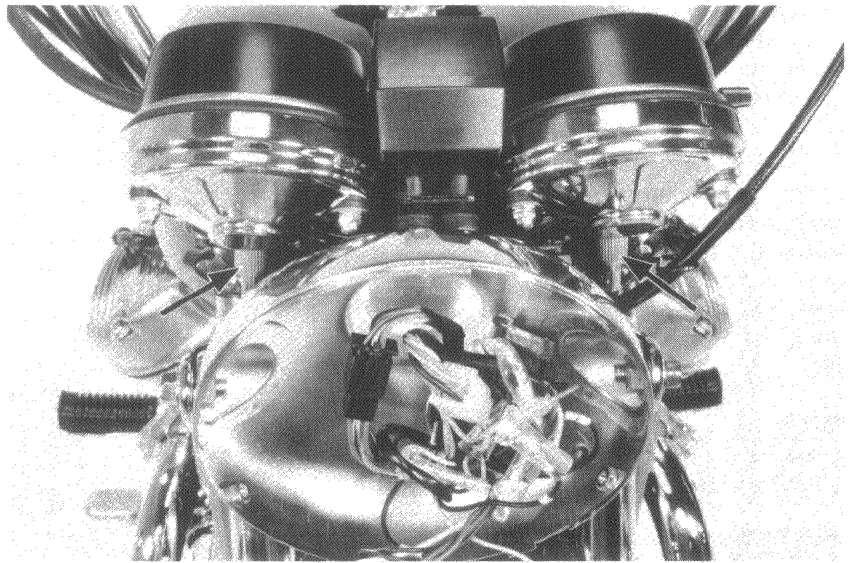

Remove the instrument mounting bolts and instruments.

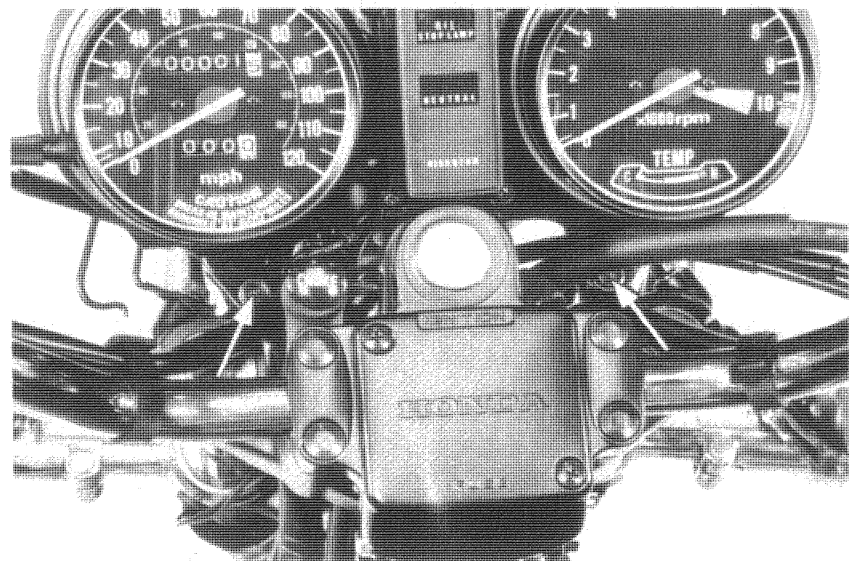



## CUSTOM : REAR SHOCK ABSORBER

### • REMOVAL

Loosen the muffler clamp bolts and remove the muffler mounting bolts.  
Remove the mufflers.

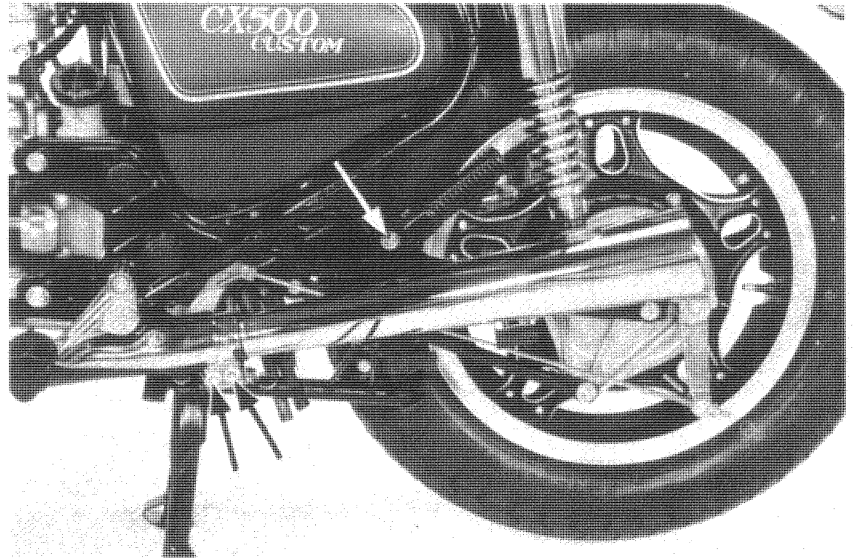

Remove the grab rail attaching bolts.  
Remove the upper and lower shock absorber mounting bolts and nuts.  
Remove the shock absorbers.

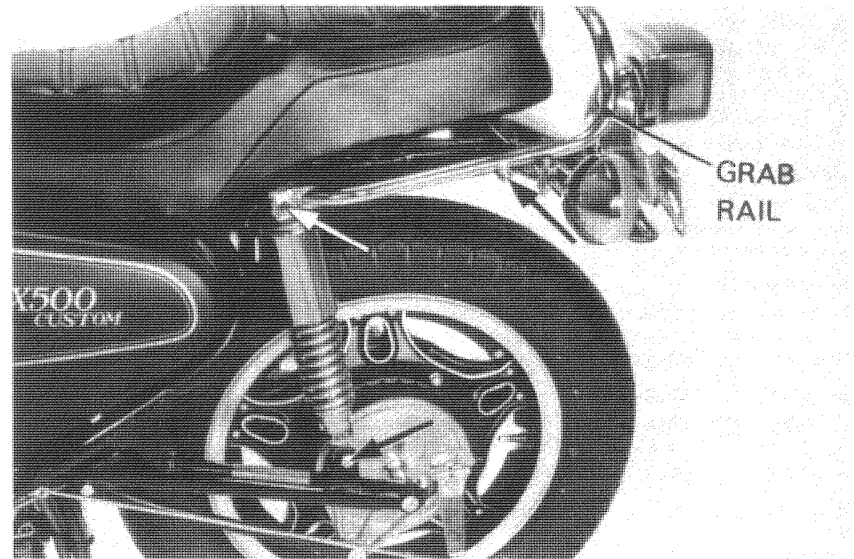

### • INSTALLATION

Tighten the shock absorber bolts and nuts.  
**TORQUE: 3.0–4.0 kg-m (22–29 ft-lb)**

Install the mufflers.

Adjust the right and left shock absorbers equally with a spanner wrench.

Check the shock absorber operation after installation.



## CUSTOM : OIL PRESSURE/ STOP LAMP WARNING INDICATOR

### ● SYSTEM TEST

Turn the ignition switch ON.  
The OIL/STOP LAMP warning indicator should go on.  
If it does not, follow the troubleshooting guide below to determine the cause.

#### Troubleshooting

1. Burnt out warning indicator
2. Open oil pressure circuit (Blue/Red wire)
3. Burnt out fuse
4. Faulty oil pressure switch

Start the engine.

The OIL/STOP LAMP warning indicator should go off.

If it does not, follow the troubleshooting guide below to determine the cause.

#### Troubleshooting

##### Engine Oil System

1. Oil level low
2. Faulty oil pressure switch
3. Plugged oil pick-up screen
4. Pressure relief valve stuck open
5. Oil pump worn or faulty
6. Oil pump drive sprocket or chain broken
7. Internal oil leakage

##### Brakelight

1. Burnt out bulb
2. Poor wire or socket connections
3. Open circuit

##### Wire Harness

1. Poor wire connections
2. Open circuit
3. Short circuit (Blue/Red to Green)

##### Stop Lamp Warning Unit

1. Internal open circuit (Green/Yellow and Green)
2. Internal short circuit (Blue/Red and Green)

### ● STOP LAMP WARNING UNIT TEST

Disconnect the warning unit coupler and remove the unit.

Connect the unit Black/Brown wire to the positive terminal of a 12V battery.

Connect the Green wire to the negative terminal.

Connect a 12V—3.4W test lamp between the Black/Brown and Blue/Red wire terminals.

Jump the Green/Yellow wire terminal to the Green wire terminal. The test lamp should go off.

Disconnect the Black/Brown wire from the battery. The test lamp should go on. If connecting the Green/Yellow wire and then reconnecting the Black/Brown wire to positive terminal, the test lamp does not go on.

Disconnect Green/Yellow wire from the Green wire. The test lamp should go on.

Reconnect the Green/Yellow wire to the Green wire. The test lamp should stay on.

Replace the unit if it does not pass the above test.

