



INTRODUCTION

This Honda Shop Manual addendum contains information for the 1980 CX500 DELUXE and CX500 CUSTOM.

Refer to the base Shop Manual for service procedures and data not included in this addendum.

ALL INFORMATION, ILLUSTRATIONS, DIRECTIONS AND SPECIFICATIONS INCLUDED IN THIS PUBLICATION ARE BASED ON THE LATEST PRODUCT INFORMATION AVAILABLE AT THE TIME OF APPROVAL FOR PRINTING. HONDA MOTOR CO., LTD. RESERVES THE RIGHT TO MAKE CHANGES AT ANY TIME WITHOUT NOTICE AND WITHOUT INCURRING ANY OBLIGATION WHATEVER. NO PART OF THIS PUBLICATION MAY BE REPRODUCED WITHOUT WRITTEN PERMISSION.

HONDA MOTOR CO., LTD.
Service Publications Office

TABLE OF CONTENTS

1. GENERAL INFORMATION	23- 2
SPECIFICATIONS	23- 2
MAINTENANCE SCHEDULE	23- 4
CABLE & HARNESS ROUTING	23- 5
2. LUBRICATION	23- 6
ENGINE OIL LUBRICATION	23- 6
CABLE LUBRICATION	23- 6
3. INSPECTION AND ADJUSTMENT ..	23- 6
SPARK PLUG	23- 6
4. FUEL SYSTEM	23- 7
CARBURETOR SPECIFICATIONS ..	23- 7
SEPARATION AND ASSEMBLY ...	23- 7
ACCELERATOR PUMP	
INSPECTION	23- 8
ACCELERATOR PUMP	
ADJUSTMENT	23- 8
PILOT SCREW REMOVAL/ INSTALLATION	23- 9
PILOT SCREW ADJUSTMENT	23- 9
IDLE LIMITER INSTALLATION ...	23-10
5. WIRING DIAGRAM	23-11



1. GENERAL INFORMATION

SPECIFICATIONS

ITEM		SPECIFICATIONS		
		CX500 DELUXE	CX500 CUSTOM	
DIMENSIONS	Overall length	2,185 mm (86.0 in)	2,150 mm (84.6 in)	
	Overall width	865 mm (34.1 in)	875 mm (34.4 in)	
	Overall height	1,165 mm (45.9 in)	1,170 mm (46.1 in)	
	Wheelbase	1,455 mm (57.3 in)	1,455 mm (57.3 in)	
	Seat height	800 mm (31.5 in)	790 mm (31.1 in)	
	Foot peg height	335 mm (13.2 in)	325 mm (12.8 in)	
	Ground clearance	145 mm (5.7 in)	145 mm (5.7 in)	
	Dry weight	205 kg (452 lb)	202 kg (445 lb)	
FRAME	Type	Diamond		
	Front suspension, travel	Telescopic fork, 139.5 mm (5.5 in)		
	Rear suspension, travel	Swingarm, 85 mm (3.3 in)		
	Front tire size	3.50S19-4PR		
	Rear tire size	130/90-16 67S		
	Cold tire pressures	Up to 90 kg (200 lbs) load	Front Rear	2.0 kg/cm ² (28 psi) 2.0 kg/cm ² (28 psi)
		Up to vehicle capacity load	Front Rear	2.0 kg/cm ² (28 psi) 2.25kg/cm ² (32 psi)
Front brake, lining swept area	Disc brake, 600 cm ² (93.0 sq in)			
Rear brake, lining swept area	Internal expanding shoes, 201 cm ² (31.2 sq in)			
Fuel capacity	17 liters (4.5 US gal)		11 liters (2.9 US gal)	
	3.5 liters (0.9 US gal)		2.5 liters (0.7 US gal)	
Caster angle	63° 15'			
Trail	105 mm (3.9 in)			
Front fork oil capacity	135 cc (4.7 ozs) After assembly			
ENGINE	Type	Liquid cooled 4-stroke OHV		
	Cylinder arrangement	2 cylinder transverse V		
	Bore and stroke	78 x 52 mm (3.07 x 2.04 in)		
	Displacement	496 cc (30.3 cu in)		
	Compression ratio	10 : 1		
	Valve train	Silent chain driven camshaft and push rod		
	Oil capacity	3.0 liters (3.2 US qt)		
	Lubrication system	Forced pressure and wet sump		
	Cooling system capacity	2.0 liters (0.52 US gal)		
	Air filtration	Paper		
	Cylinder compression	12 kg/cm ² (171 psi)		
	Intake valve	Opens Closes	6° BTDC (at 1 mm lift), 79° BTDC (at 0 lift) 46° ABDC (at 1 mm lift), 123° ABDC (at 0 lift)	
	Exhaust	Opens Closes	46° BBDC (at 1 mm lift), 114° BBDC (at 0 lift) 6° ATDC (at 1 mm lift), 85° ATDC (at 0 lift)	
	Valve clearance	IN: 0.08 mm (0.003 in) EX: 0.10 mm (0.004 in)		
	Engine weight	65 kg (143.3 lb)		
Idle speed	1,100 ± 100 rpm			



HONDA CX500

'80 ADDENDUM

ITEM		SPECIFICATIONS																																	
		CX500 DELUXE			CX500 CUSTOM																														
CARBURETION	Carburetor type	CV 34 mm (1.3 in)																																	
	Identification number	VB28A			VB25A																														
	Pilot screw Float level	See page 23-9 15.5 ± 1 mm (0.61 ± 0.04 in)																																	
DRIVE TRAIN	Clutch	Wet, multi-plate																																	
	Transmission	5-speed, constant-mesh																																	
	Primary reduction	2.242																																	
	Gear ratio I	2.733																																	
	Gear ratio II	1.850																																	
	Gear ratio III	1.416																																	
	Gear ratio IV	1.148																																	
	Gear ratio V	0.931																																	
Final reduction	3.091 (11/34)																																		
Gear shift pattern	Left foot operated return system 1-N-2-3-4-5																																		
ELECTRICAL	Ignition	CDI																																	
	Ignition timing "F" mark	15° BTDC/1,100 ± 100 rpm																																	
	Full advance	37° ± 3° BTDC																																	
	RPM from "F" to full advance	1,750-6,000 rpm																																	
	Starting system	Starting motor only																																	
	Generator	Three phase A.C. generator 170W/5,000 rpm																																	
	Battery capacity	12V-14AH																																	
	Spark plug	<table border="1"> <thead> <tr> <th></th> <th colspan="2">For cold climate below 5°C (41°F)</th> <th colspan="2">Standard</th> <th colspan="2">For extended high speed riding</th> </tr> <tr> <th>USA model</th> <th>ND</th> <th>NGK</th> <th>ND</th> <th>NGK</th> <th>ND</th> <th>NGK</th> </tr> </thead> <tbody> <tr> <td></td> <td>X22ES-U</td> <td>D7EA</td> <td>X24ES-U</td> <td>D8EA</td> <td>X27ES-U</td> <td>D9EA</td> </tr> <tr> <th>Canadian model</th> <td>X22ESR -U</td> <td>DR7ES</td> <td>X24ESR -U</td> <td>DR8ES -L</td> <td>X27ESR -U</td> <td>DR8ES</td> </tr> </tbody> </table>							For cold climate below 5°C (41°F)		Standard		For extended high speed riding		USA model	ND	NGK	ND	NGK	ND	NGK		X22ES-U	D7EA	X24ES-U	D8EA	X27ES-U	D9EA	Canadian model	X22ESR -U	DR7ES	X24ESR -U	DR8ES -L	X27ESR -U	DR8ES
		For cold climate below 5°C (41°F)		Standard		For extended high speed riding																													
	USA model	ND	NGK	ND	NGK	ND	NGK																												
	X22ES-U	D7EA	X24ES-U	D8EA	X27ES-U	D9EA																													
Canadian model	X22ESR -U	DR7ES	X24ESR -U	DR8ES -L	X27ESR -U	DR8ES																													
Spark plug gap	0.6-0.7 mm (0.024-0.028 in)																																		
Fuse	20A (main), 10A (sub)																																		
LIGHTS	Headlight (high/low beam)	65/50W sealed beam																																	
	Tail/stoplight	8/27W (3/32 cp SAE NO. 1157)																																	
	Turn signal light (front/rear)	23/23W (32/32 cp SAE NO. F. 1034, R. 1073)																																	
	Speedometer light	3.4W (2 cp SAE NO. 57)																																	
	Tachometer light	3.4W (2 cp SAE NO. 57)																																	
	Neutral indicator	3.4W (2 cp SAE NO. 57)																																	
	Turn signal indicator	3.4W (2 cp SAE NO. 57)																																	
	High beam indicator	3.4W (2 cp SAE NO. 57)																																	
Running light	8W (3 cp SAE NO. 1034)																																		



MAINTENANCE SCHEDULE DELUXE AND CUSTOM

Perform the PRE-RIDE INSPECTION in the Owner's Manual at each scheduled maintenance.

I: INSPECT AND CLEAN, ADJUST, LUBRICATE OR REPLACE IF NECESSARY.

C: CLEAN

R: REPLACE

A: ADJUST

L: LUBRICATE

FREQUENCY	WHICHEVER COMES FIRST	ODOMETER READING [NOTE 3]								REFER TO	
		EVERY	600 mi. (1,000 km)	3,750 mi. (6,000 km)	7,500 mi. (12,000 km)	11,250 mi. (18,000 km)	15,000 mi. (24,000 km)	18,750 mi. (30,000 km)	22,500 mi. (36,000 km)		
ITEM											
EMISSION RELATED ITEMS	* FUEL LINES				I			I		I	Page 3-3
	* THROTTLE OPERATION		I		I			I		I	Page 3-5
	* CARBURETOR-CHOKE				I			I		I	Page 3-6
	AIR CLEANER	NOTE 1		C	R	C	R	C	R	C	Page 3-2
	CRANKCASE BREATHER	NOTE 2		C	C	C	C	C	C	C	Page 3-3
	SPARK PLUGS			R	R	R	R	R	R	R	Page 23-6
	* VALVE CLEARANCE		I	I	I		I		I		Page 3-4
	ENGINE OIL	YEAR	R		R		R		R		Page 2-2 23-6
	ENGINE OIL FILTER	YEAR	R		R		R		R		Page 2-2
	* CAM CHAIN TENSION		A	A	A	A	A	A	A	A	Page 3-5
	* CARBURETOR-SYNCHRONIZE		I		I		I		I		Page 3-7
	* CARBURETOR-IDLE SPEED		I	I	I	I	I	I	I	I	Page 3-6
	* RADIATOR COOLANT				I		I		R		Page 3-8 9-3
	* RADIATOR CORE				I		I		I		Page 3-8
* COOLING SYSTEM, HOSES & CONNECTIONS		I		I		I		I		Page 3-8	
NON-EMISSION RELATED ITEMS	* DRIVE SHAFT JOINT				L			L		L	Page 2-3
	* FINAL DRIVE LUBRICANT				I			I		R	Page 2-3
	BATTERY	MONTH	I	I	I	I	I	I	I	I	Page 3-9
	BRAKE FLUID (FRONT)	MONTH 2 YEARS *R	I	I	I	I	I	I	I	*R	Page 3-9
	BRAKE SHOE/PAD WEAR			I	I	I	I	I	I	I	Page 3-11
	BRAKE SYSTEM (REAR)			I	I	I	I	I	I	I	Page 3-11
	* BRAKE LIGHT SWITCH			I	I	I	I	I	I	I	Page 3-12
	* HEADLIGHT AIM			I	I	I	I	I	I	I	Page 3-13
	CLUTCH			I	I	I	I	I	I	I	Page 3-13
	SIDE STAND				I		I		I		Page 3-14
	* SUSPENSION			I	I	I	I	I	I	I	Page 3-14
	* NUTS, BOLTS, FASTENERS			I	I	I	I	I	I	I	Page 3-15
** WHEELS			I	I	I	I	I	I	I	Page 3-15	
** STEERING HEAD BEARING			I	I	I	I	I	I	I	Page 3-15	

* SHOULD BE SERVICED BY AN AUTHORIZED HONDA DEALER, UNLESS THE OWNER HAS PROPER TOOLS AND SERVICE DATA AND IS MECHANICALLY QUALIFIED.

** IN THE INTEREST OF SAFETY, WE RECOMMEND THESE ITEMS BE SERVICED ONLY BY AN AUTHORIZED HONDA DEALER.

- NOTE:
1. Service more frequently when riding in dusty areas.
 2. Service more frequently when riding in rain or at full throttle, or after being washed or overturned.
 3. For higher odometer readings, repeat at the frequency interval established here.



CABLE & HARNESS ROUTING

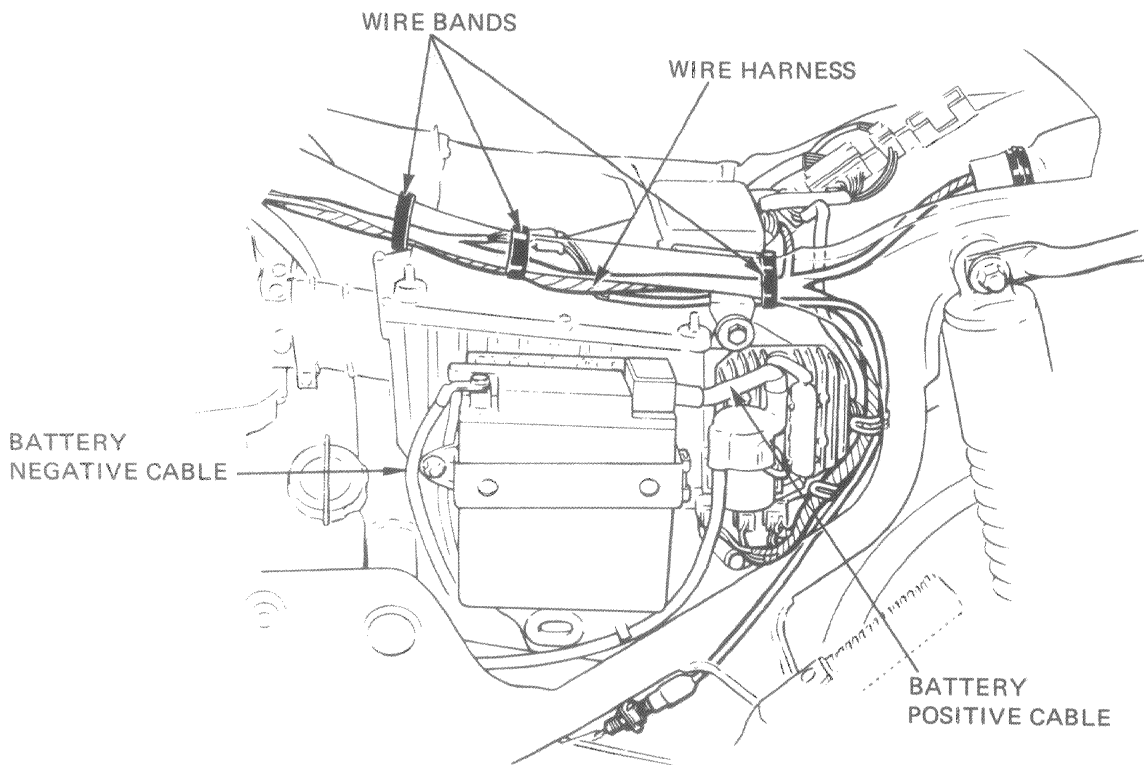
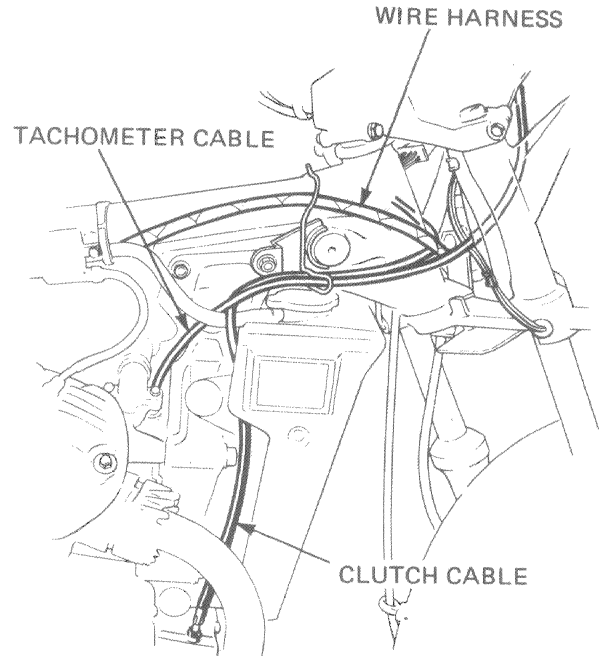
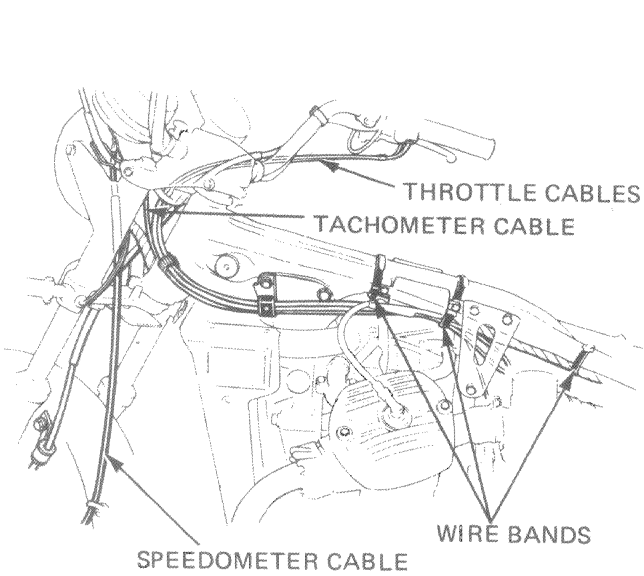

2. LUBRICATION

ENGINE OIL RECOMMENDATION

Use HONDA 4-STROKE OIL or equivalent.

API SERVICE CLASSIFICATION: SE

VISCOSITY: SAE 10W-40

Other viscosities shown in the chart may be used when the average temperature in your riding area is within the indicated range

OIL VISCOSITIES

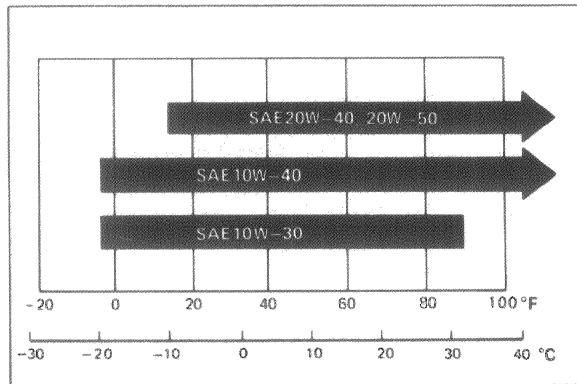

CABLE LUBRICATION

Lubricate the clutch, choke and throttle cables with a commercially available cable lubricant to prevent premature wear and corrosion.

3. INSPECTION AND ADJUSTMENT

SPARK PLUG

Disconnect the spark plug caps.

Clean any dirt from around the spark plug base.

Remove and discard the spark plugs.

Check the new spark plug gaps with a wire type feeler gauge.

If adjustment is necessary, bend the side electrode carefully.

SPARK PLUG GAP:

0.6-0.7 mm (0.024-0.028 in)

With the plug washers attached, thread the new spark plugs in by hand to prevent crossthreading.

Tighten the spark plugs 1/2 turn with a spark plug wrench.

Install the spark plug caps.

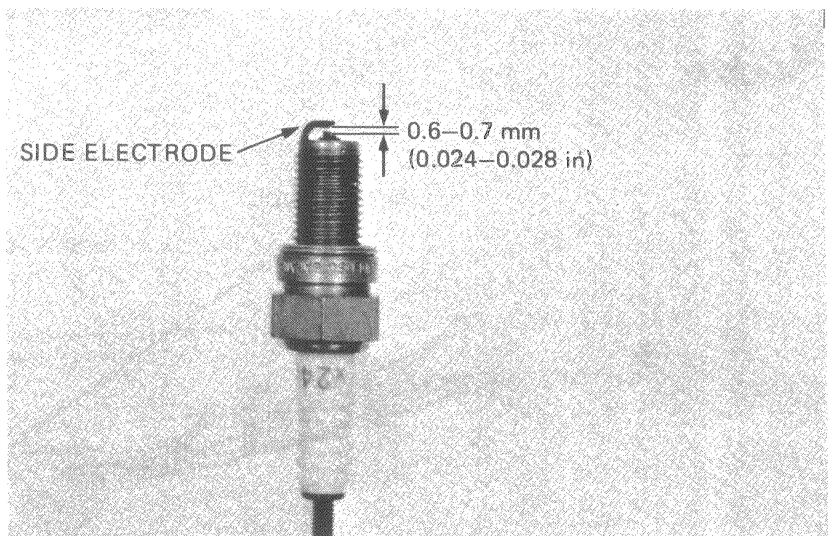

RECOMMENDED SPARK PLUG:

	For cold climate below 5°C (41°F)		Standard		For extended high speed riding	
	ND	NGK	ND	NGK	ND	NGK
USA model	X22ES-U	D7EA	X24ES-U	D8EA	X27ES-U	D9EA
Canadian model	X22ESR-U	DR7ES	X24ESR-U	DR8ES-L	X27ESR-U	DR8ES



4. FUEL SYSTEM

GENERAL INFORMATION

- The CX500 carburetor bore size has been changed to 34 mm (1.3 in).
- An accelerator pump circuit has been added.
- See Caution and Note under Pilot Screw Removal and Pilot Screw Adjustment (Page 23-10).

CARBURETOR SPECIFICATIONS

	CX500 DELUXE	CX500 CUSTOM
Identification mark	VB28A	VB25A
Idle speed	1,100 ± 100 rpm	←
Fast idle speed	1,000 – 1,500 rpm	←
Float level	15.5 ± 1 mm	←
Pilot screw	See page 23-9	←
Bore	34 mm	←
Main jet	Primary #78	←
	Secondary #115	←

CARBURETOR SEPARATION

Remove the carburetors (Page 4-2).
Separate the carburetors (Page 4-3), noting that the accelerator pump joint pipe must be removed.

ASSEMBLY

Install a new O-ring on each end of the accelerator pump and fuel joint pipes.
Assemble the right and left carburetors noting the compression spring location.
Install the front and rear stays.
Refer to page 4-9 for carburetor installation.

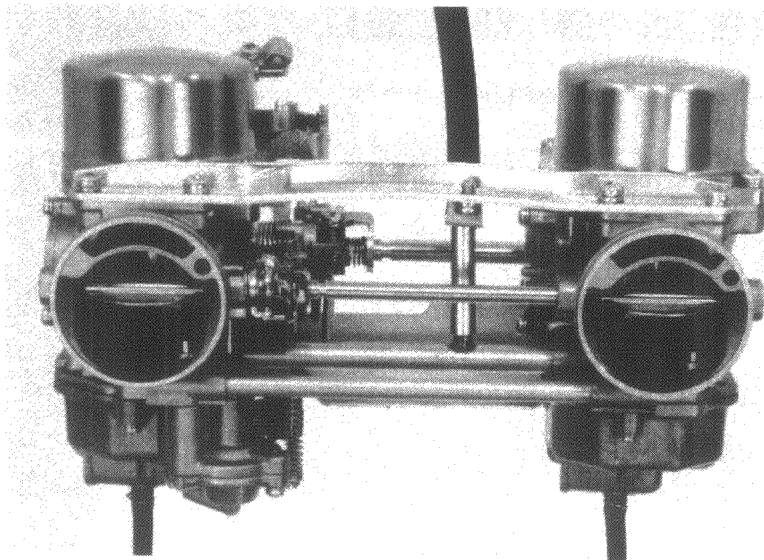



ACCELERATOR PUMP INSPECTION

Remove the accelerator pump by unscrewing the setting screw.

Remove the accelerator pump cover and spring.

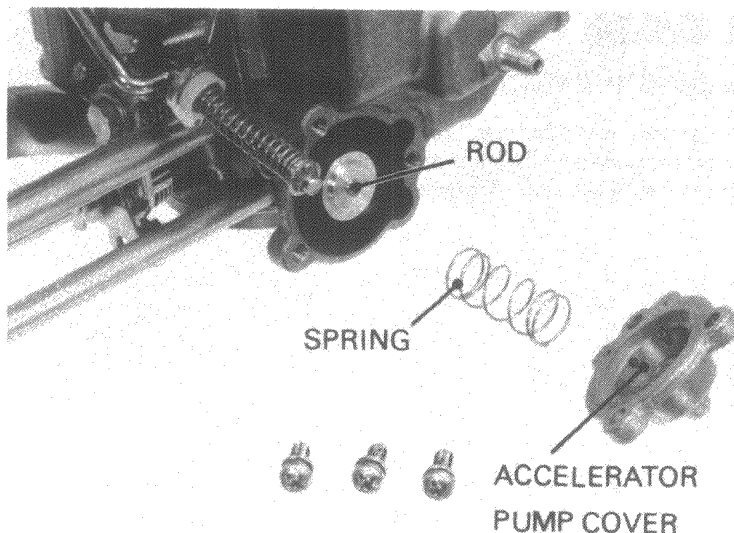

Remove the diaphragm.
Inspect the diaphragm for cracks and brittleness.
Replace if necessary.
Be sure the accelerator rod is not bent.

Assemble the accelerator pump in the reverse order of disassembly.

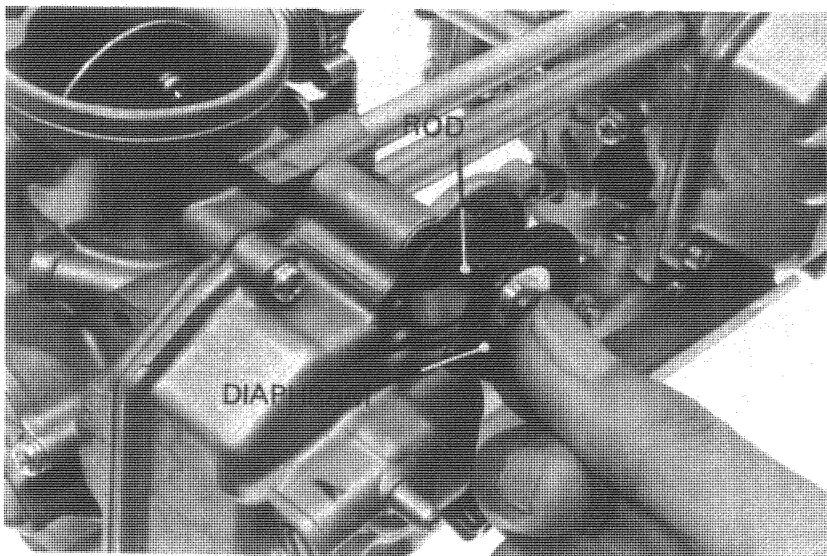

ACCELERATOR PUMP ADJUSTMENT

Loosen the throttle stop screw, so the throttle valve is closed.

Measure the clearance between the accelerator pump rod and the adjusting arm with the throttle valve closed.

CLEARANCE: 0.1–0.3 mm
(0.004–0.012 in)

Adjust by bending the adjusting arm.

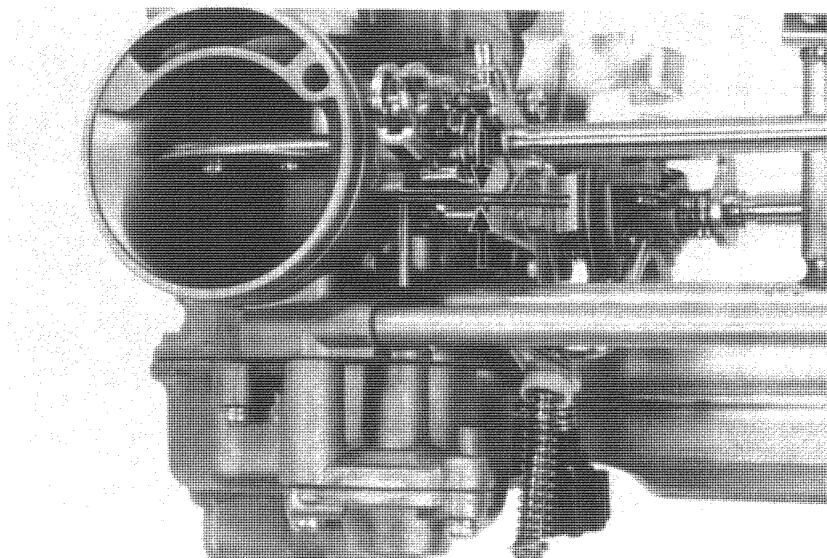



Measure the clearance between the adjusting arm and stopper on the carburetor.

CLEARANCE: 3.1–3.3 mm (0.12–0.13 in)

Adjust by bending the adjusting arm.

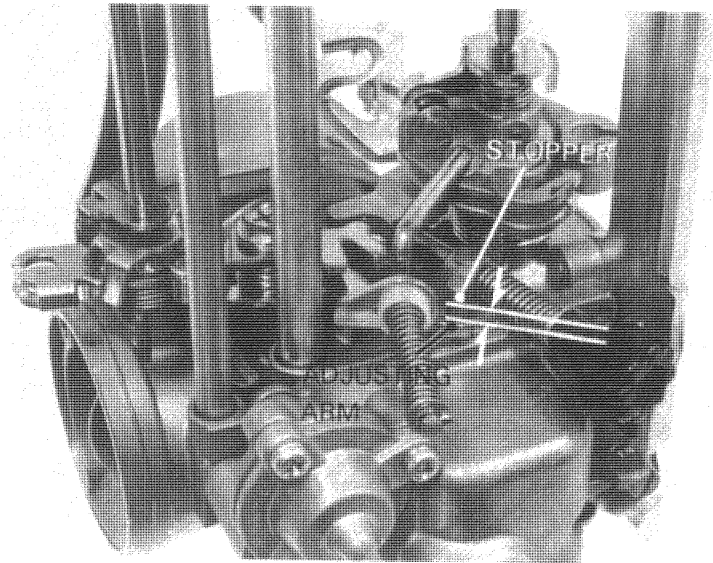

PILOT SCREW REMOVAL/ INSTALLATION

NOTE

The pilot screws are factory pre-set and should not be removed unless the carburetors are overhauled.

CAUTION

Any forcible attempt to remove the pilot screw limiter caps will cause screw breakage.

Remove the carburetors (page 4-2).
Remove the float chamber (page 4-6).

Turn the pilot screw in and carefully count the number of turns before it seats lightly. Make a note of this to use as a reference when reinstalling the pilot screws.

CAUTION

Damage to the pilot screw seat will occur if the pilot screw is tightened against the seat.

Remove the pilot screw.
Inspect the pilot screw for wear and replace if necessary.
Install the pilot screw and turn it to the original position, as noted during removal. Perform pilot screw adjustment if a new pilot screw is installed. (See below)

NOTE

Do not install limiter caps on new pilot screws until after adjustment has been made (See page 23-11).

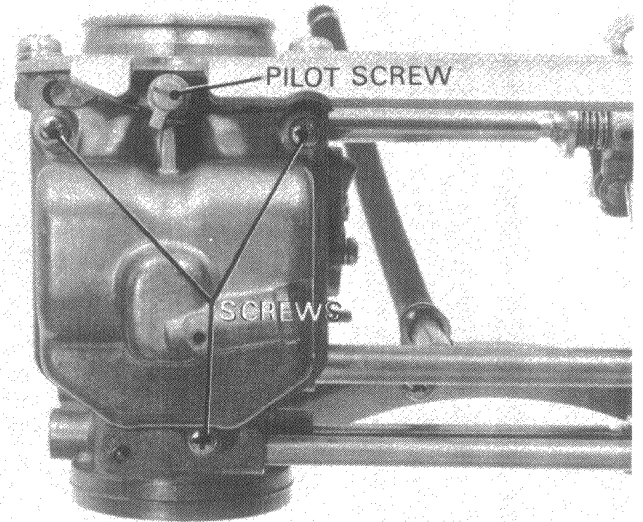

PILOT SCREW

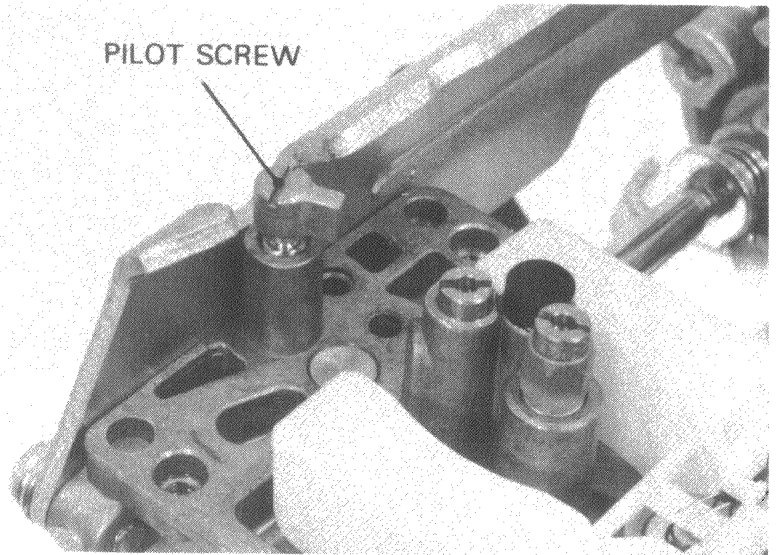

PILOT SCREW ADJUSTMENT

Adjust the pilot screws (page 4-10), using 1-3/4 turns as the pilot screw initial opening.



IDLE LIMITER INSTALLATION

After adjustment, cement the limiter caps over the pilot screws, using LOCTITE® #601 or equivalent. The limiter cap should be placed against its stop, preventing further adjustment that would enrich the fuel mixture (limiter cap position permits clockwise rotation and prevents counterclockwise rotation).

NOTE

- Do not turn the pilot screws when installing the limiter caps.
- Pilot screw limiter caps must be installed. They prevent misadjustment that could cause poor performance and increase exhaust emissions.

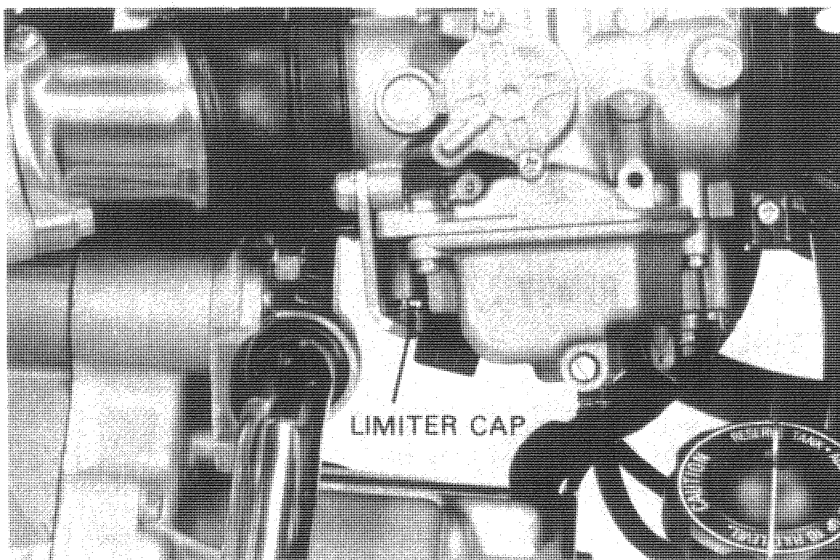



CX500

'80 ADDENDUM

5. WIRING DIAGRAM CX500 DELUXE

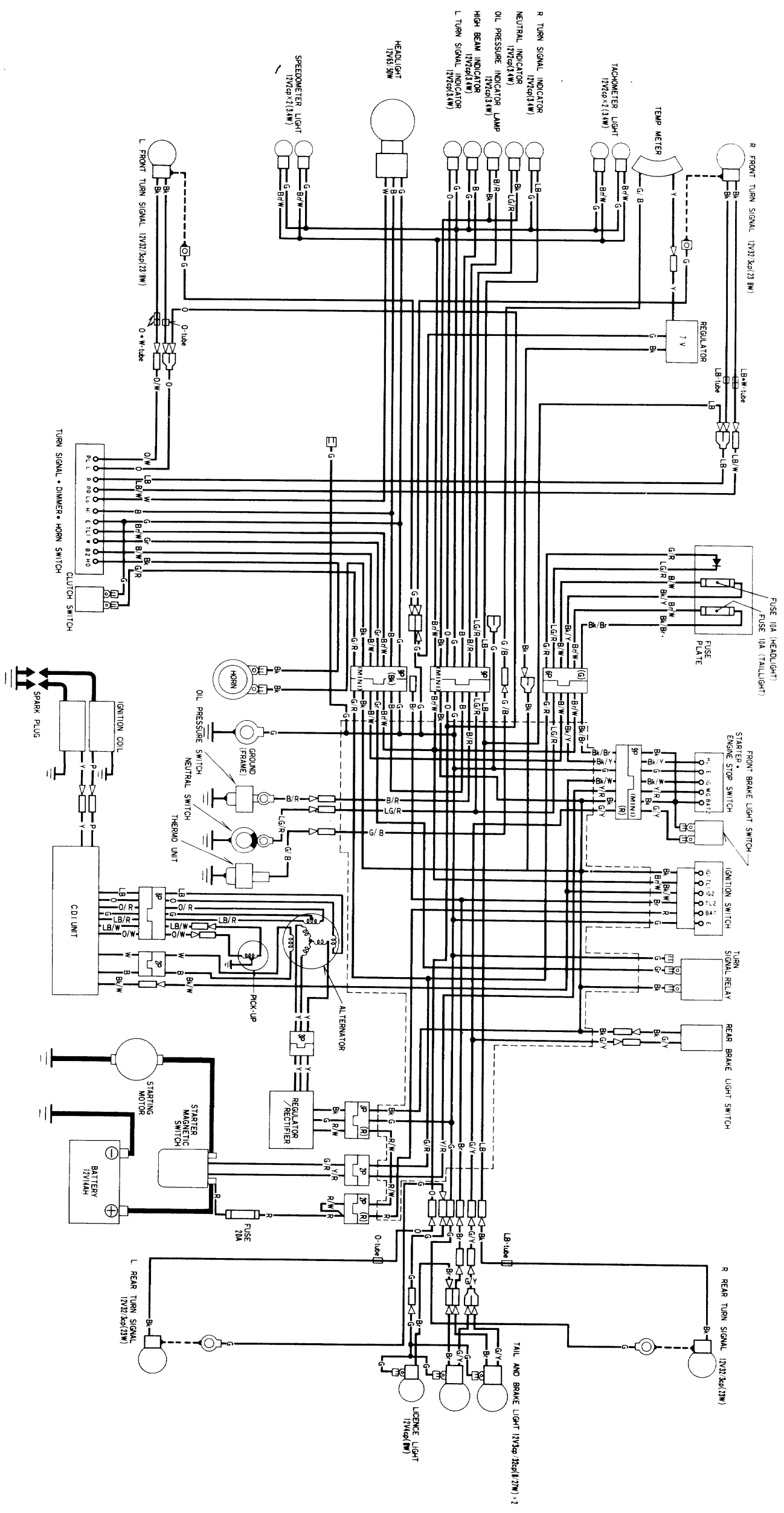

IGNITION SWITCH CONTINUITY

	E	IG2	BAT	IG1	TL1	TL2
OFF	○	○	○	○	○	○
ON	○	○	○	○	○	○
P	○	○	○	○	○	○
LOCK	○	○	○	○	○	○

STARTER-ENGINE STOP SWITCH CONTINUITY

	ENGINE STOP SWITCH	STARTER SWITCH	MAG BATT2	H/L
OFF	○	○	○	○
FREE	○	○	○	○
PUSH	○	○	○	○
OFF	○	○	○	○

TURN SIGNAL • DIMMER • HORN SWITCH CONTINUITY

	B2	L3	H1	H0	E	W	R	L	TL1	PR	PL
○	○	○	○	○	○	○	○	○	○	○	○
FREE	○	○	○	○	○	○	○	○	○	○	○
PUSH	○	○	○	○	○	○	○	○	○	○	○
H	○	○	○	○	○	○	○	○	○	○	○

TURN SIGNAL SWITCH CONTINUITY

	B2	L3	H1	H0	E	W	R	L	TL1	PR	PL
○	○	○	○	○	○	○	○	○	○	○	○
FREE	○	○	○	○	○	○	○	○	○	○	○
PUSH	○	○	○	○	○	○	○	○	○	○	○
L	○	○	○	○	○	○	○	○	○	○	○

- B Brown
- Bk Black
- W White
- LG Light Green
- R Red
- G Green
- Y Yellow
- B Blue
- Gr Grey
- LB Light Blue
- O Orange
- P Pink

0030Z-470-6700

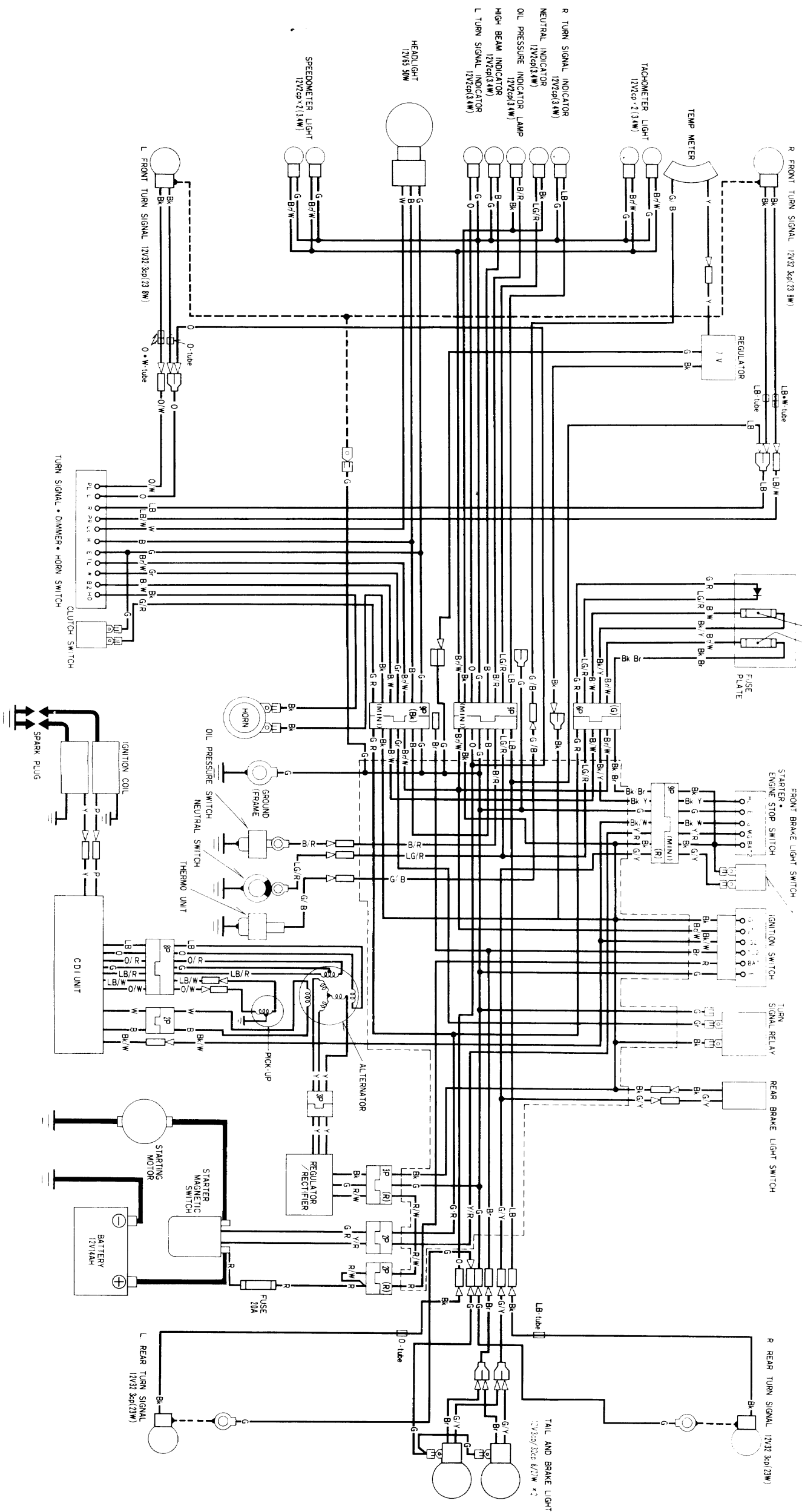

IGNITION SWITCH CONTINUITY

	E	IG2	BAT	IG1	TL1	TL2
OFF	○	○	○	○	○	○
ON	○	○	○	○	○	○
P	○	○	○	○	○	○
LOCK	○	○	○	○	○	○

STARTER ENGINE STOP SWITCH CONTINUITY

	IG	E	FREE	MAG	BAT2	H/L
OFF	○	○	○	○	○	○
RUN	○	○	○	○	○	○
OFF	○	○	○	○	○	○

TURN SIGNAL • DIMMER • HORN SWITCH CONTINUITY

	B2	L3	H	FREE	H0	E	R	R	L	TL	PR	PL
OFF	○	○	○	○	○	○	○	○	○	○	○	○
ON	○	○	○	○	○	○	○	○	○	○	○	○
LOCK	○	○	○	○	○	○	○	○	○	○	○	○

WIRE COLOR CODES

Bk	Brown	Y	Yellow
Bk	Black	B	Blue
W	White	G	Grey
L/G	Light Green	LB	Light Blue
R	Red	O	Orange
G	Green	P	Pink

0030Z-449-7700